

Design Codes
Final report
March 2023



Quality review

Project role	Name	Position	Action summary	Signature	Date
Qualifying Body	Ruth Bryer	NP Group Chairman	Final comments	Ruth Bryer	28-02-2023
Director	Ben Castell	Director	Amendments post-Reg 14 consultation	Ben Castell	23-02-2023
Director / QA	Ben Castell	Director	Revision and approval of Draft Final Report	Ben Castell	01-05-2022
Qualifying Body	Ruth Bryer	NP Group Chairman	Draft Report Submitted for comments	Ruth Bryer	17-02-2022
Director / QA	Ben Castell	Director	Revision and approval of Draft Final Report	Ben Castell	16-12-2021
Researcher	Alejandro de Miguel Solano	Senior Urban Designer	Revision, research, written content, drawings	Alejandro de Miguel Solano	16-12-2021
Researcher	Chatnam Lee	Graduate Urban Designer	Baseline analysis	Chatnam Lee	16-12-2021

This document has been prepared by AECOM Limited ("AECOM") in accordance with its contract with Locality (the "Client") and in accordance with generally accepted consultancy principles, the budget for fees and the terms of reference agreed between AECOM and the Client. Any information provided by third parties and referred to herein has not been checked or verified by AECOM, unless otherwise expressly stated in the document. AECOM shall have no liability to any third party that makes use of or relies upon this document.

Contents

1a. Scoping	5	2d. Applied design codes	95
1b. Baseline	9	3. Delivery	99
Policy review	10		
Road & street hierarchy	12		
Green infrastructure	14		
Blue infrastructure	16		
Heritage	18		
Heritage assets	20		
2a. Design vision	23		
Movement	25		
Nature	26		
Built Form	27		
Identity	27		
Public space	28		
Uses	28		
Homes & buildings	29		
Energy & sustainability	29		
2b. Area types	31		
2c. Design codes	35		
Movement	38		
Nature	46		
Built Form	56		
Identity	60		
Public space	72		
Uses	80		
Homes & buildings	82		
Energy & sustainability	88		





1a

Scoping

The structure of this report follows these steps

1a

Scoping - Introduction to the objectives and methodology for the report

1b

Baseline - Initial analysis of the physical conditions and relevant policies

2a

Design vision - Aims for future development

2b

Area types - Identify the different areas to apply the design codes

2c

Design codes - Design actions and guidance for developments

2d

Applied Design Code - Summary of design codes and where they are applicable

03

Next steps - Delivery and how this guide can be used by different stakeholders

Scope

AECOM has been commissioned to provide design support to Ickleford Parish Council through the Department for Levelling Up, Housing and Communities technical support programme, led by Locality.

This document supports the Neighbourhood Plan policies that guide the assessment of future development proposals and encourage high-quality design.

Objective and Method

This document develops design codes to guide any future development in the area. It gathers the residents' aspirations and the work being undertaken in the drafting of the emerging neighbourhood plan policies to produce design codes that respond to, retain and enhance the intrinsic features of the area.

The key steps in the method to produce these design codes are:

1b. Baseline: the review of the existing policy together with the analysis of the physical characteristics of the area, constitutes the base to understand the objectives and aims for the plan and the residents' input into design.

2a. Design vision: the proposed design codes need to be based on a design vision for how a place can develop in the future. The vision can be understood as the set of ambitions that the design codes will need to respond to.

2b. Area types: area types with common features are identified in this section. They will be used to identify the locations with specific characteristics where the conditions detailed in the design codes apply.

2c. Design codes: the design codes constitute the specific design actions that any future development will need to implement if it wants to be successful. They are organised following the categories outlined in the design vision.

Area of study

Ickleford is located in North Hertfordshire, to the north of Hitchin and in close proximity to Letchworth Garden City, Lower Stondon and Pirton.

Historically, its origin can be traced back to the 12th century, where the village developed around the estates of Lord Ickleford and Lord Ramerick, as well as around the 12th century Norman church - St Katharine's church. It consisted mostly of rural farmlands and a collection of cottages and some 16th and 17th century farmhouses.

Today it is a relatively large village boasting one primary school, a village hall, three pubs and a large sports and recreation ground.

At the 2011 census, Ickleford had 1,833 residents.

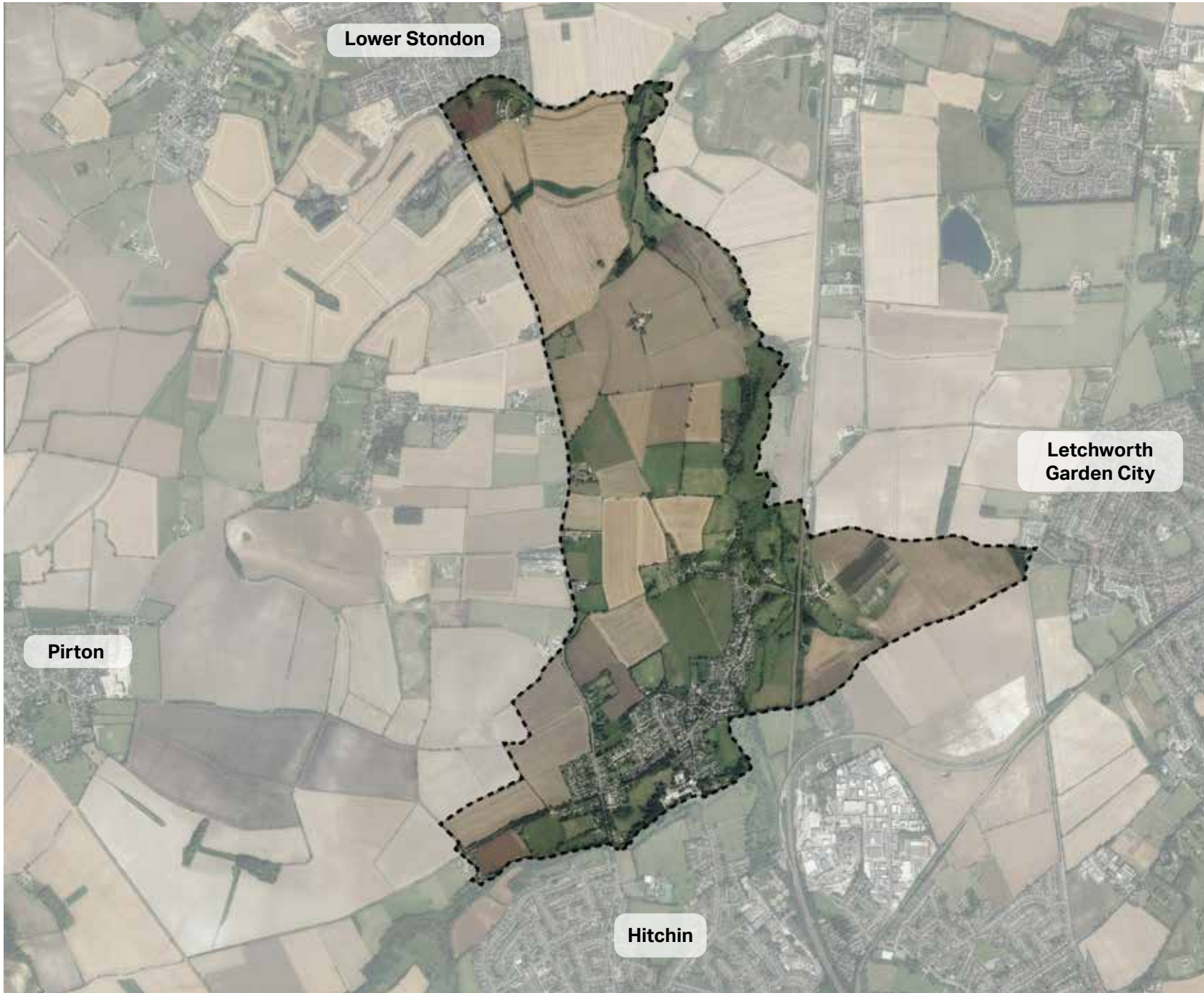

Figure 01:
NP boundary map

Key
- - - NP Boundary





1b

Baseline

Policy review

This policy review ensures that the design codes in the following sections are up to date with the latest guidance. New proposals should be aware and respond to the latest policies and guidelines at the different governance levels.

The documents and reports in this and the next page have informed the current document. These guidelines have been produced at national, district or neighbourhood area level.

This section specifies how the specific policies and guidelines have been incorporated in the production of the design codes included in the current document.

New planning applications should be familiar with these documents and make explicit reference to how each of them is taken into account in the proposal.

National policy & guidance



Planning for the Future

**Ministry of Housing,
Communities & Local
Government**

2020

The White Paper proposes a new planning system reform, as a step into stronger neighbourhood planning.

This paper can be understood as an attempt to consolidate design codes, not merely as guidelines but as rules. These are to be prepared locally and to be based on community involvement so that local residents have a genuine say in the design of new development.

The Current Document and the design codes herein should be read in the light of the White Paper.



Building for a Healthy Life

Homes England

2020

The Building for a Healthy Life report (BHL) updates the original Building for Life 12 report, a widely-used design tool for creating better places for people and nature.

The original 12 point structure and underlying principles within Building for Life 12 are at the heart of BHL.

The BHL report should be read in conjunction with the design codes in the Current Document to achieve the best possible outcome.



National Design Guide

**Ministry of Housing,
Communities & Local
Government**

2019, updated 2021

The National Design Guide (NDG) underlines that creating high quality buildings and places is a fundamental outcome of the planning and development process.

This guide illustrates how well-designed places that are beautiful, enduring and successful can be achieved in practice.

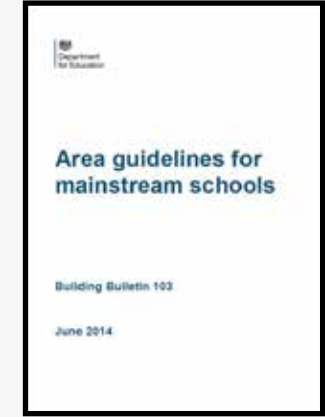

Area Guidelines for Mainstream Schools

**Department of
Education**

2014

These guidelines provide standards and recommendations for the provision of new school buildings and their grounds

The guide also provides guidance in estimating the built and ground area needed for new schools.

Local policy & guidance

NP policy & guidance

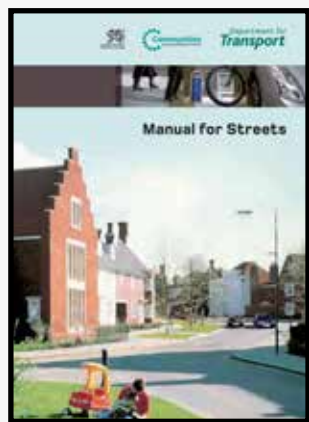

Manual for Streets
Department for Transport
2007

This manual presents standards and best practice on street design.

This manual has informed the design codes.

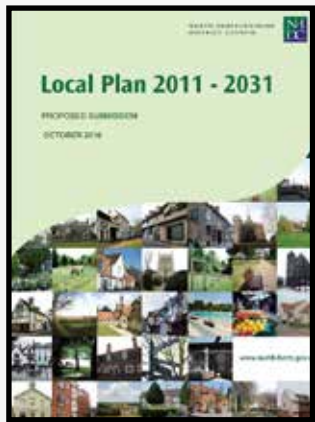

Local Plan
North Hertfordshire District Council
2022

The Local Plan sets out the level of growth that needs to be planned for in the district, where it should be located and how it should be delivered. It also sets out the planning policies which the Council will use in determining planning applications.

A new Local Plan (2011-31; pictured) was adopted in November 2022. It allocates 3 housing sites in the village of Ickleford, for the delivery of approximately 199 new homes.



Local Plan Policies Map
North Hertfordshire District Council
2016

The Local Plan Policies Map details the main urban areas, and land allocated for employment, retail, infrastructure, housing, natural environment and conservation areas.

This policies map complements the Local Plan in specifying boundaries for different area types, as well as the locations where Local Plan policies are applicable.

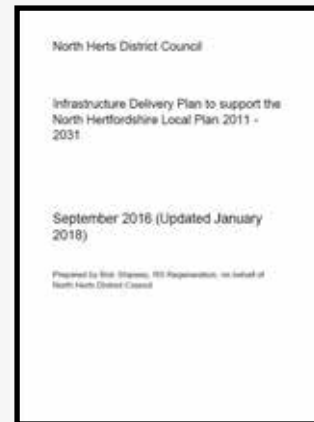

Infrastructure Delivery Plan (IDP)
North Hertfordshire District Council
2011

The IDP identifies infrastructure requirements arising from the local authority's Local Plan, to support growth within the district up to 2031. These requirements are typically focused on needs associated with housing growth, as well as other site allocations and policies - such as employment.

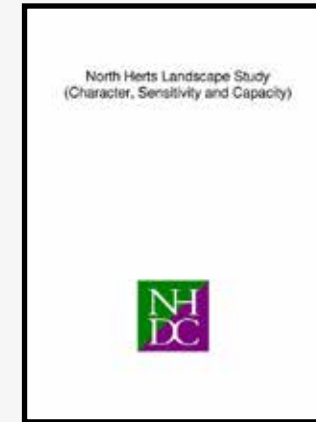

North Herts Landscape Character Assessments (LCA)
North Hertfordshire District Council
2011

The district based LCA provide details into the different landscape features that make up the landscape character of the district. Guidelines on conservation and improvement are provided, which should be taken into consideration where new developments are anticipated in sites of protected landscape.

LCA provisions for Ickleford are provided within Areas 217 (River Oughton and Purwell Valleys) and 218 (Pirton Lowlands). Some of the notable landscape features include deciduous woodlands and parkland which should be carefully preserved.



Ickleford NP Consultation
Ickleford NP Group
2021

The NP consultation included a comprehensive survey of 45 questions. Overall, 355 responses were collected with a 43% response rate.

The consultation was an important resource in accessing residents' views and visions for the future of Ickleford.

It also forms a strong basis for the current document, where aspirations of local residents will be a key driver for the development of the design codes.

Road & street hierarchy

The village of Ickleford is connected via a north-south axis to Hitchin and an east-west axis to Letchworth Garden City.

The key routes of Turnpike Lane and Arlesey Road and the more minor route of Chambers Lane intersect to form the main centre of Ickleford village. A series of residential streets with a suburban character branch out from these roads.

Key routes

Ickleford is located to the north of the market town of Hitchin and west of Letchworth Garden City. Located east-west across the village is Turnpike Lane, which becomes Westmill Lane extending west and merges with Arlesey Road approaching southeast of the village. Bedford Road (A600) provides north-south access along the southwestern side of the village. These roads collectively form the arterial access routes of Ickleford and the intersection of these roads forms the village hub, where shops, pubs and the village hall are located.

Residential streets

Branching out north and south from these arterial routes is a network of secondary and tertiary roads, providing access to residential areas of the village. Ickleford also boasts an extensive network of public footpaths along the edges of the village, providing easy access for walkers and cyclists to nearby fields and farmlands. The historical Icknield Way is one of the public footpaths leading out of Ickleford and provides a scenic route to the nearby Letchworth Garden City.

Rural to suburban transition

There is a quick transition from the rural landscape along the A600, into a more suburban residential character approaching Ickleford village. The green gap providing separation between Ickleford and Hitchin is of tremendous importance to local people. Recent planning decisions have eroded the gap.



Figure 02:
Intersection of Turnpike Ln and Arlesey Rd at the village centre



Figure 03:
Approach to Ickleford village via Bedford Road (A600)



Figure 04:
Road & street hierarchy map

Key

- Parish Boundary (in white)
- Primary road
- Secondary road
- Tertiary road
- Public Footpaths
- Railway
- Housing sites in Local Plan

Green infrastructure

The landscape of Ickleford consists mostly of farmlands and woodlands, within the Green Belt surrounding the immediate vicinity of the village.

Ickleford also falls within a SSSI Impact Risk Zone of a nearby SSSI site in Westmill. Future planning applications should be mindful of impacts to the site.

Landscape Designation

The south-western part of Ickleford falls within a 2km radius of the Site of Special Scientific Interest (SSSI) Impact Risk Zone of the Oughtonhead Lane SSSI in Westmill (to the southwest of Ickleford). Any future planning applications within the area would need to consider any potential impacts and risks posed to the SSSI.

Habitats

The immediate vicinity of Ickleford village is characterised by farmlands and woodlands that fall within the Ickleford Parcel of the North Hertfordshire District Green Belt, which plays a critical role to prevent urban sprawling north of Hitchin and countryside encroachment.

The agricultural nature of the surrounding area of Ickleford contributes positively to its rural character. Much of the woodlands surrounding Ickleford are broadleaved woodlands, along with stretches of deciduous woodlands. New developments in Ickleford should take careful consideration of any impacts to these classified woodland areas.



Figure 05:
Farmland at the edge of Ickleford



Figure 06:
Woodland with broadleaved and deciduous trees - landscape that is typically found in Ickleford



Figure 07:
Green infrastructure map

Key

- Parish Boundary (in white)
- Roads (in white)
- Housing sites in Local Plan
- Green Belt

Habitats

- Broadleaved woodland
- Deciduous woodland
- Traditional orchards

Landscape Designation

- SSSI Impact Risk Zone

Blue infrastructure

Ickleford is home to the confluence of the River Oughton, which flows along the southwestern edge of the village, and the River Hiz, flowing along its northeastern edge - adding to the village's character whilst providing a valuable piece of natural amenity to local residents. However, areas immediately adjacent to the rivers are subjected to flood risk with some of these being residential areas.

Rivers and Water bodies

Ickleford is located in close proximity to the River Hiz, which flows from Hitchin to Arlesey, and its tributary, the River Oughton, which rises in Oughtonhead. Not only do these add to the character of Ickleford, they are also important natural amenities for residents. The confluence of the two rivers is located to the southeast of the village.

These rivers are rare Chalk Streams. There are only about 200 Chalk Streams in the world, most of them are in the South East of England. Their care may require a different approach to other rivers. The River Hiz Conservation Group is working with the Herts and Middlesex Wildlife Trust to look after the river.

According to the National Flood Warning mapping system, the outskirts of Ickleford is subjected to risks of flooding from the rivers with some of these areas being residential in the southern side of the village. However, much of areas currently prone to flooding are uninhabited farmland and woodland.

Flood Risks and Development Sites

In terms of impact on designated development sites, both IC1 and IC2 are located relatively close to River Oughton, as well as their flood risk catchment areas. New development on these sites should take into consideration any potential flood risk.



Figure 08: River flowing through wooded parts of Ickleford - adding to its character and scenery



Figure 09: Some residential areas are located in close proximity to the river



Figure 10:
Blue infrastructure map

Key

- Parish Boundary (in white)
- Roads (in white)
- River and water body
- Housing sites in Local Plan

River and water body flooding

- Flood risk (higher)
- Flood risk (lower)

Heritage

Farmhouses, cottages and barns dated from the 16th to 18th century are commonly listed as heritage assets in Ickleford - contributing towards its rural character.

Ickleford was first recorded as "Ickleinford" in the 12th century. The village became a vicarage in 1215 - serving two separate manors owned by the Lord of Ickleford and Lord of Ramerick. Some buildings from the two manors remain evident in Ickleford to date, including the Old Manor Cottage and the Clock House in the heart of the village on Turnpike Lane.

However, there is evidence that suggests the area existed as early as the Neolithic and Bronze age - palaeolithic tools were previously found close to New Ramerick Farm.

The Parish has over 30 Grade I and Grade II listed structures and a conservation area located in the centre, covering an area across Arlesey Road, Turnpike Lane and Chambers lane.

Most of the Parish's listed heritage can be found within the conservation area, with some farmhouses and barns extending to the north and south of the area. Many of these structures are cottages and farmhouses of significant architectural and historical value built between the 16th and 18th century. A key landmark in the village is the Grade I listed Church of St Katharine, which was first built in the 12th century and was restored by the Parish in 1859.



Figure 11:
Old George Inn (c.1910)



Figure 12:
View towards Ickleford Manor (c.1910)

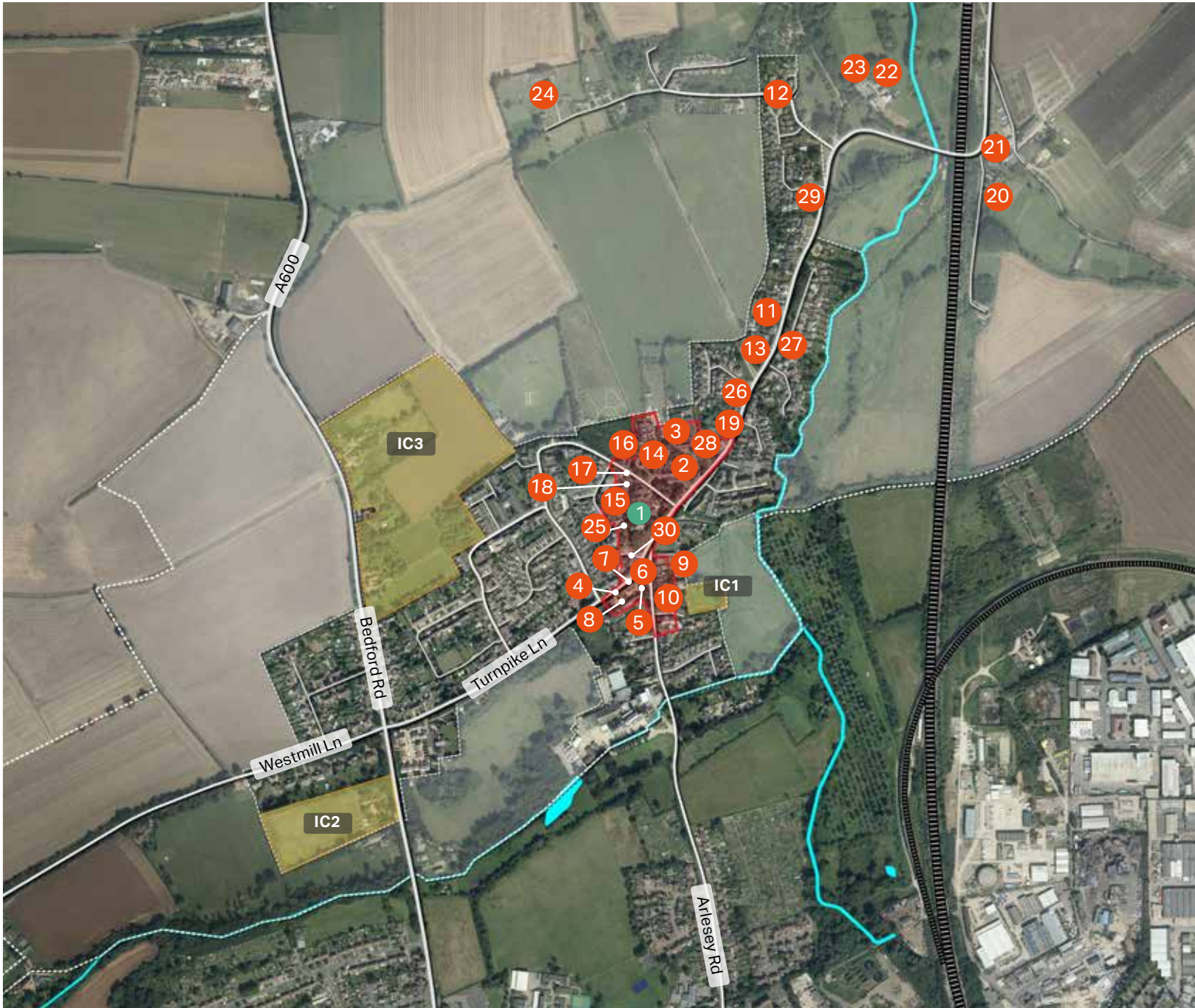

Figure 13:
Heritage map

Key

- Parish Boundary (in white)
- Roads (in white)
- Conservation Area
- Grade I
- Grade II
- Housing sites in Local Plan

Heritage assets

The following is a series of designated heritage assets found across the Parish of Ickleford that contribute positively to its local character

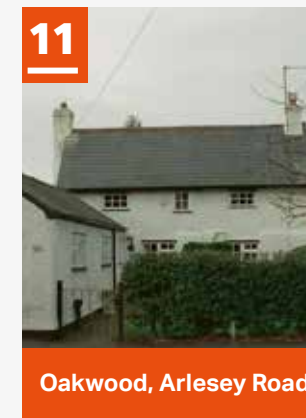
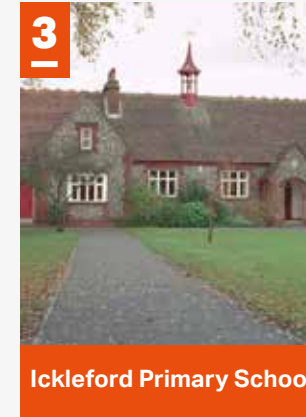
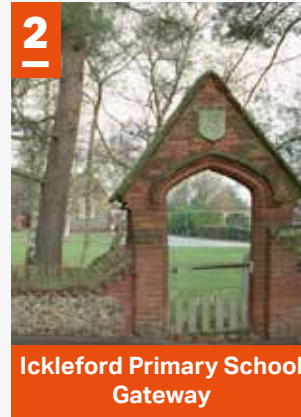



13

77, Arlesey Road



14

The Cottage, Upper Green



15

Greenfield Cottage, Greenfield Lane



16

Arnold's Farm, Upper Green



17

Plume of Feathers Public House



18

St Katharines Cottages, Upper Green



19

Clive Cottage, Arlesey Road



20

Lynburn, Arlesey Road



21

Cadwell Farm, Arlesey Road



22

Lower Green Farmhouse, Snailswell Lane



23

Lower Green Farmhouse Barn, Snailswell Lane



24

Sycamore Cottage, Snailswell Lane



25

3-5 Church Path



26

88, Arlesey Road



27

Old Farm Cottage, Arlesey Road



28

Rose Cottage, Arlesey Road

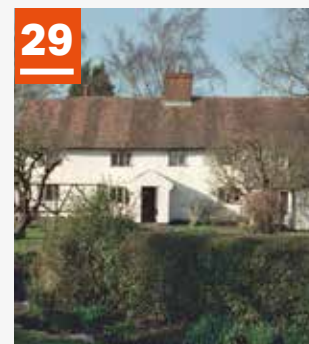

29

Long Meadow, Arlesey Road



30

The Old George Inn, Arlesey Road





2a

Design vision

Design vision

The objectives in this section establish a design vision for Ickleford. They are aligned to both the objectives of the Local Plan and those of the Neighbourhood Plan area in a seamless fashion, one that is coherent with the needs of the District as a whole and specific to the Parish in particular.

This section establishes the objectives that any development in the area should aim for. They can be understood as the vision to be satisfied by any new development proposal in Ickleford.

This overarching vision will crystallize and will be further detailed in specific design actions in the next sections as design codes.

The vision objectives outlined in this section are classified under the following topics: movement, nature, built form, identity, public space, uses, homes & buildings and energy & sustainability.



Movement

Well-designed places should be accessible and easy to move around. This can be achieved through a connected network of streets, good public transport, the promotion of walking and cycling and well-considered parking and servicing.



MO.01

MO.01 Connectivity

A well connected network provides a variety of streets to move around a place. It is direct, allowing efficient movement. It is safe and attractive to pedestrians and cyclists.



MO.02

MO.02 Public transport

Access to public transport is key to providing people with choice for everyday journeys beyond the immediate neighbourhood. Good access to public transport helps reduce reliance on cars.



MO.03

MO.03 Wayfinding

Making walking and cycling comfortable and attractive for all users is about making it easy to move around the streets, so wayfinding and orientation come naturally to all.

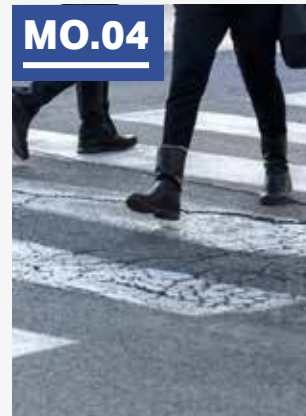

MO.04

MO.04 Junctions

Junctions and crossings should be designed in accordance with Manual for Streets to be safe, convenient and attractive for all users.



MO.05

MO.05 Inclusive streets

Successful street design addresses needs of older people in the outdoor environment to remove physical barriers and improve the movement and accessibility of everyone.



MO.06

MO.06 Car parking

Well-considered parking is convenient, safe and attractive to use. It is also well integrated into streets, and does not visually dominate the local environment.



MO.07

MO.07 Cycle storage

The need for secured spaces for bicycles is a consequence of the emphasis on active travel. Cycle storage should be designed to avoid clutter on the streetscape.

Nature

New developments will need to take a proactive approach to mitigate their impact and to adapt to the specific landscape within and surrounding the area.

New developments should also look to actively tackle climate change to future-proof the proposals, taking into account the long-term implications for flood risk, biodiversity and landscapes.

New developments should mitigate any detrimental effects that they impose on the natural environment, while enhancing the existing landscape features and promoting habitat creation.

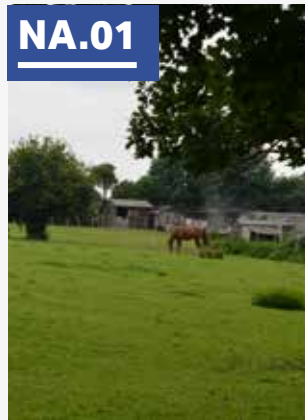

NA.01

NA.01 Green Belt

Development will be resisted in Green Belt land, to safeguard sufficient land for agriculture, forestry and outdoor leisure.



NA.02

NA.02 Green networks

Green spaces deliver a wide range of environmental and quality of life benefits. Green networks cover everything from country parks to green roofs and street trees.

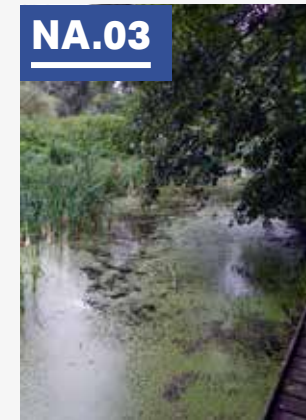

NA.03

NA.03 Design with water

Managing water is an important element of a site's response to climate. It can reduce flood risk and improve water quality while providing habitats and recreation.



NA.04

NA.04 SuDS

Sustainable drainage systems are strategies to reduce the rate of rainwater run-off from development, mitigating the risk of flooding elsewhere whilst delivering benefits for biodiversity, water quality and amenity.



NA.05

NA.05 Net-gain

New development should result in a minimum 10% net increase in biodiversity compared to the situation prior to development



NA.06

NA.06 Biodiversity

New development should improve existing habitats or create new ones to achieve measurable gains for biodiversity. This can include landscaping and tree planting.



NA.07

NA.07 Street planting

Trees on streets provide habitat, shading, cooling, air quality improvements and carbon sequestration, as well as being a vital component of attractive places.



NA.08

NA.08 Woodland

Woodland can help increase biodiversity, provide shelter, prevent soil erosion, and reduce flooding.

Built Form

Built form refers to the three-dimensional arrangement of buildings, and blocks. The layouts, forms, types, scales and heights constitute the fundamental elements of the built environment that define what a particular area is. These characteristics will vary considerably in each design code area type.

Identity

The character of a place is made of many different elements that come together to create a unique sense of identity.

New developments will need to respect the existing character as well as create attractive and authentic places that contribute positively to the townscape, public realm and setting of the Area.



BF.01 Density

Density is one indicator for how compact a development or place will be and how intensively it will be developed. Density in new developments should be appropriate to the context.



BF.02 Types & forms

The size, shape and arrangement of both buildings and blocks is at the base of the character of an area.



BF.03 Heights

Building heights and scale, the skyline, key views and vistas and the relative prominence of landmark buildings can influence the character of an area.



BF.04 Building line

This line represents the alignment of the front face of the buildings in relation to a street or other public space. The relation of the building line to the street contribute to the character of an area.



ID.01 Local character

Character is the quality that makes a place special and fixes it in the memory of residents and visitors. It is a consequence of the combination of many factors.



ID.02 Legibility

The legibility of a place relates to how easy it is for people to find their way around. Including legibility and wayfinding principles into design improves the experience of a place.

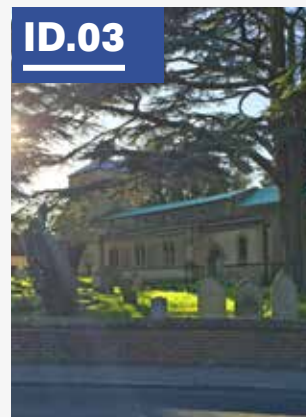

ID.03 Heritage assets

Heritage assets constitute referential elements that consolidate the identity of a community. New developments should respect and enhance heritage assets and their setting.



ID.04 Plots & blocks

Some architectural features, such as brickwork, colour patterns or window details are part of a material tradition of places that contribute positively to the identity of a place.

Public space

If the built form section refers to the formal characteristics of buildings, the public space section refers to the formal characteristics of streets. Streets are the main component of the public space and are defined primarily by their degree of enclosure with buildings and trees, and will vary considerably by design code area type.

Uses

Sustainable places include a mix of uses that support everyday activities for users to live, work and play.

New developments can provide additional functions to only residential use, to satisfy the needs of residents. They should encourage inclusive places, that cater for the different needs or different types of people maximising the activation of the public realm.

PS.01



PS.01 Access street

These streets carry local traffic and provide access into new developments; they are often the location of community facilities and can be residential streets in themselves.

PS.02



PS.02 Residential street

These streets manage traffic flows to prioritise active travel. They provide access to homes and support social interaction and health and wellbeing.

PS.03



PS.03 Edge lane

With no through traffic, these are used for servicing or for access to small groups or clusters of homes and are directly in contact with the green edges of the settlement.

PS.04



PS.04 Secured by design

Neighbourhoods need to be designed to make people feel safe and to reduce the incidence of crime.

US.01



US.01 Shops

Small convenience shops can contribute to the livelihood of a new development, while serving both the community and the new residents.

US.02



US.02 Community uses

Larger schemes should result in a spatial provision for new community facilities and related amenity space.

Homes & buildings

Well-designed homes and buildings are functional and accessible. They allow for change over time and provide sufficient amenity space within them for users to thrive.

Energy & sustainability

New developments should meet the needs of the present without compromising the ability of future generations to meet theirs.

New proposals should balance out the negative environmental impact of development by use of better design, higher efficiency in the consumption of energy and materials in the entire life cycle of buildings and adequate management of waste.

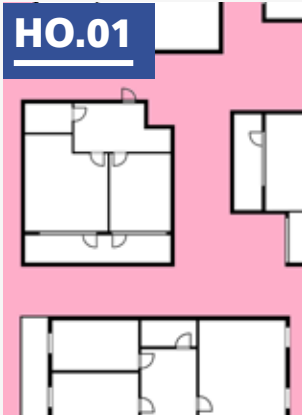

HO.01

HO.01 Space standards

Space standards are minimum requirements for internal space within new dwellings and include Gross Internal (floor) Area, and dimensions for rooms and floor to ceiling heights.



HO.02

HO.02 Accessibility

Accessible homes can be easily reached, entered and used by everyone, regardless of age and physical ability. They are flexible and can accommodate change in use and user needs.

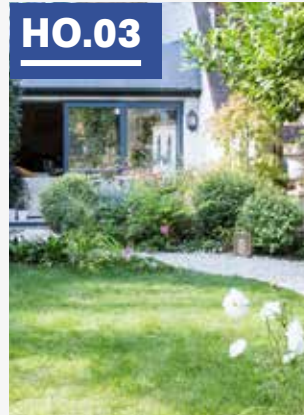

HO.03

HO.03 Garden & boundary

A considerable amount of time is spent daily in the home environment. Access to external private space is important for people's wellbeing.



HO.04

HO.04 Extensions

Flexible homes should be able to accommodate change over time. These should be done in a way that works with the existing dwelling and the area it is inserted into.



SU.01

SU.01 Low carbon

Energy efficient homes combine all around energy efficient construction, appliances, and lighting with commercially available renewable energy systems.



SU.02

SU.02 Insulation

Well insulated constructions help reduce heat loss, water and air infiltration, improving comfort and reducing energy consumption.



SU.03

SU.03 Solar panels

Photovoltaic panels that produce electricity and solar thermal panels that are used for heating purposes can make use of the energy from the sun for home use.



SU.04

SU.04 Green roofs

A green roof is covered with vegetation planted over a waterproofing membrane. They can absorb rainwater, provide insulation and improve wildlife.





2b

Area types

Area types

The identification of area types and their attributes can help understand the nature of the design codes in the Neighbourhood Plan area, to identify challenges and specific issues common to a number of locations that the design codes need to target.

The different areas displayed on the map in the next page have emerged from the following analysis:

- How has the village developed historically. What is its position in the landscape, and how this should influence any future growth.
- What are the factors that make the area distinctive and different from others. What are the vernacular features of architecture in the area and what are the most frequent building typologies.
- How does the green and blue infrastructure (including open spaces and vegetation features) contribute to the area and how these, and other aspects of value, should be subject to protection.
- How do the street pattern, the street scene, the walking and cycling networks and the traffic and parking provision affect the perception of the different areas.
- What is the typical plot type in each area. How many levels do residential buildings display and what is the average density of dwellings in the area.



Area type A. Historic Core

The area contains a large proportion of listed and historic buildings. Dwellings are predominantly detached and present traditional building systems, contributing positively to the character of Ickleford.



Area type B. Settlement

These areas comprise the bulk of the built areas, ranging from the expansions of the post-war period to recent developments. They tend to lack listed or locally listed buildings. Dwellings are predominantly semi-detached and terraced.



Area type C. Rural Countryside

A number of arable fields to the north of the neighbourhood plan area are not included under the Green Belt designation, and are more susceptible to development as a result. The proximity of this area to Stondon makes a joint approach between authorities advisable.



Area type D. Green Belt

The built areas in Ickleford are surrounded by Green Belt designated land. This area constitutes the underlying landscape base, essential to the character of the neighbourhood area.



Area type E. New development

An additional area, not specifically linked to a specific location, will be used in the design codes in the next sections to refer to new developments in any of the previous areas.

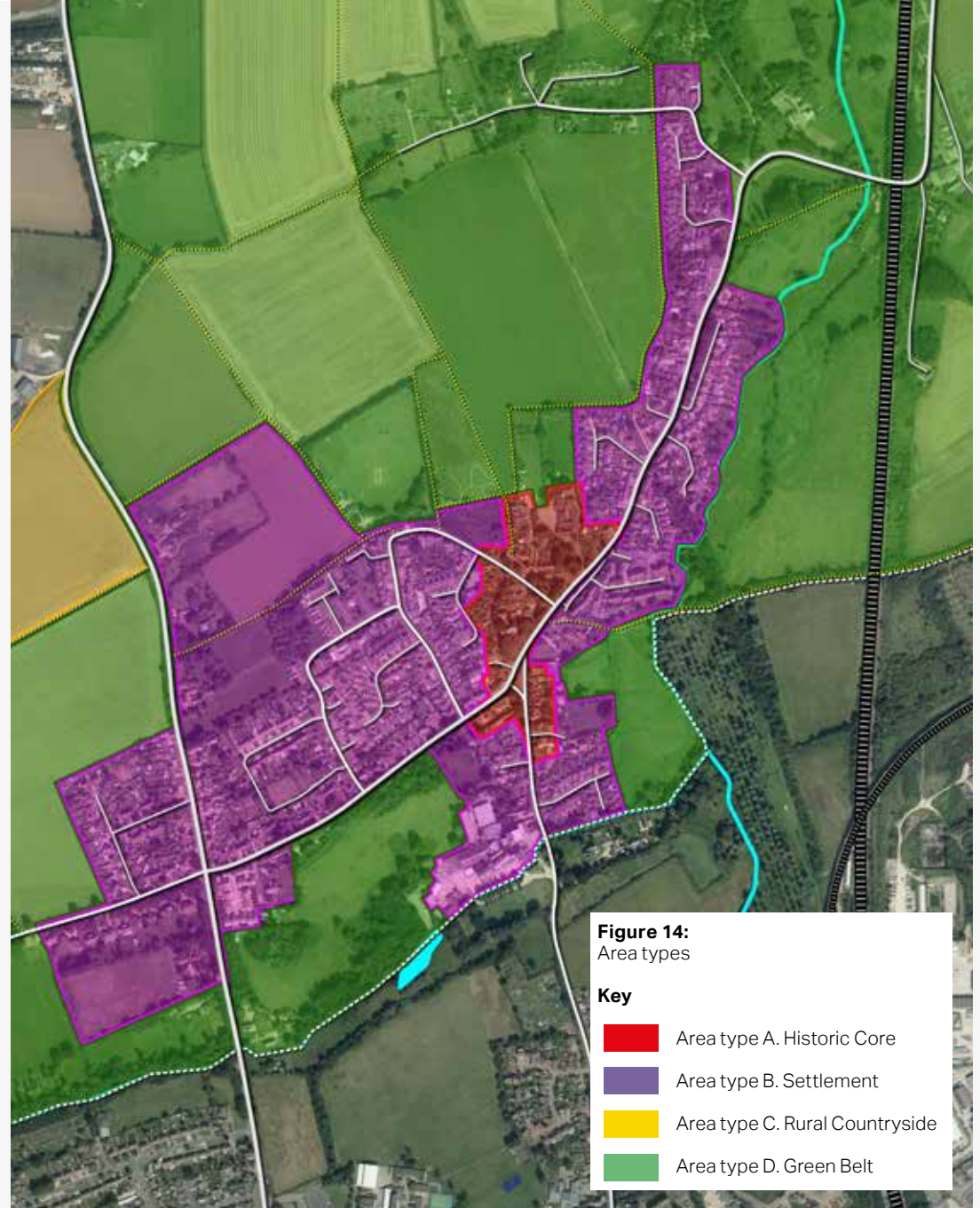
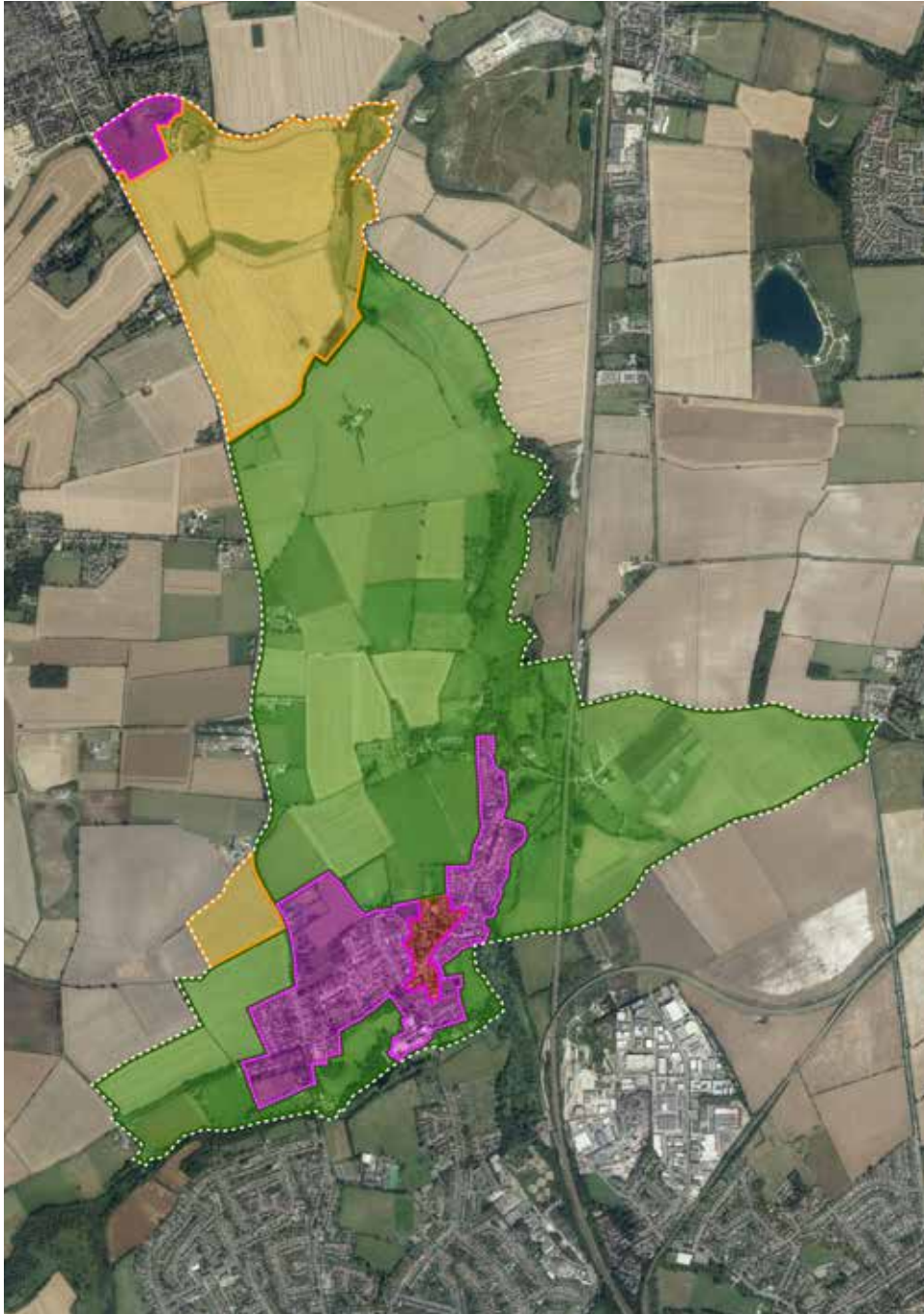

Figure 14:
Area types

Key

- Area type A. Historic Core
- Area type B. Settlement
- Area type C. Rural Countryside
- Area type D. Green Belt





2c

Design codes

How to read the design codes

The design codes detailed in this section will follow this structure consistently.

They indicate the design principle to which they belong and their name and ID code at the top left of the page.

The content of each design code includes:

- **Guidance & Requirements**

The design codes include general design guidance that recommends good practices in relation to design but also include specific actions (requirements) that will be sought out in relation to new development.

In the text, the latter will be headed by the word *Actions* and followed by the specific conditions that are to be satisfied.

- **Illustrative diagrams**

The written guidance and requirements will be further detailed with illustrations and diagrams.

- **Areas of application**

The top of the page includes a colour code to indicate in which area type the code is applicable.

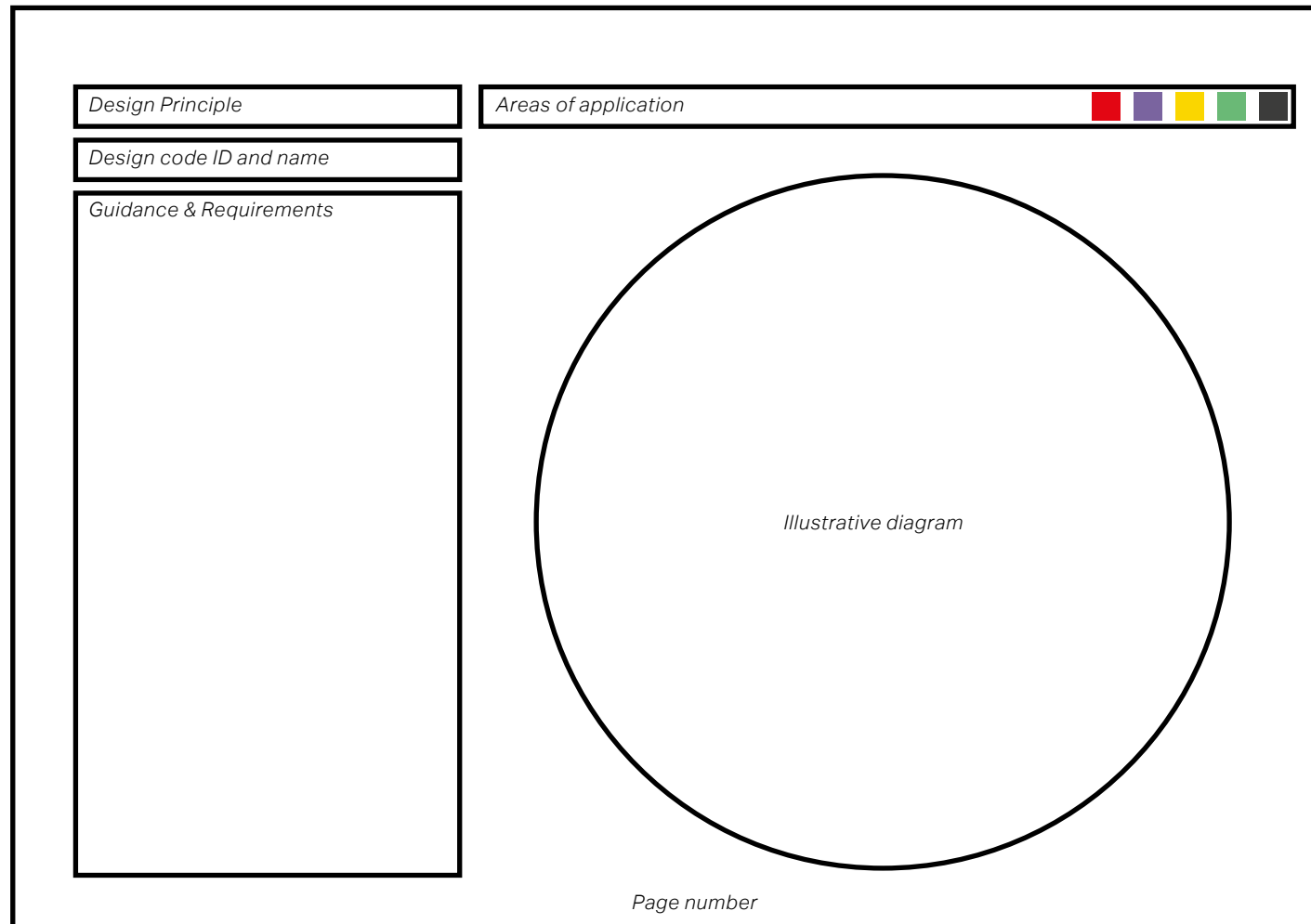

Sample design code page to be found in the current section



This code is applicable to the following character areas:
(Those areas where it is applicable are highlighted in colour)

Example 1: this code would be applicable only on area types C and D

This code is applicable to the following area types:
(Those areas where it is applicable are highlighted in colour)



Example 2: this code would be applicable only on area type E: New development

This code is applicable to the following area types:
(Those areas where it is applicable are highlighted in colour)



Areas of application

The design codes in this section are applicable to the area types signalled in section 2b. A new area is included in the design code to refer to areas of future development, whose character is still to be defined.

Existing area types

Four existing area types have been identified in Ickleford based on the criteria detailed in section 2b. These character areas are:

- Area type A: Historic Core
- Area type B: Settlement
- Area type C: Rural countryside
- Area type D: Green Belt

New development

Should new development come forward in other areas of Ickleford, whether that is through Green Belt release (as anticipated) or otherwise, then there are specific codes that should apply, and are different to those that are based on development coming forward in an existing area with its own, existing character.

An additional character area will be included in the design codes section (3a) to encompass any new developments that could come forward in the neighbourhood plan area, and that could constitute a new area type of their own.

This character area is:

- Area type E: New development

Movement

MO.01 Connectivity

Links to the countryside & natural spaces

The neighbourhood plan area boasts high quality natural habitats where woodlands coexist with arable fields.

Actions:

- Create links with the countryside. In edge locations, consider connecting all streets to the network of public pathways and rights of way.
- Consider rivers, watercourses and waterfronts as part of a network of natural spaces to reverse the effects of biodiversity fragmentation.
- Retain approach routes and the perception of the natural landscape when approaching the settlement, keeping the gradual transition from open spaces to built areas.

Make use of the agricultural landscape

Actions:

- Promote safe accessible paths & corridors within agricultural fields with the potential to connect rural settlements to their hinterland.

New developments

Actions:

- Make the best use of existing public transport services and improve safe walking and cycling paths.
- Locate development where the need to travel will be minimised.
- Limit any significant impacts from and to the development of the highways and transportation network.
- Maximise road and street network connectivity.

This code is applicable to the following area types:
(Those areas where it is applicable are highlighted in colour)

A

B

C

D

E

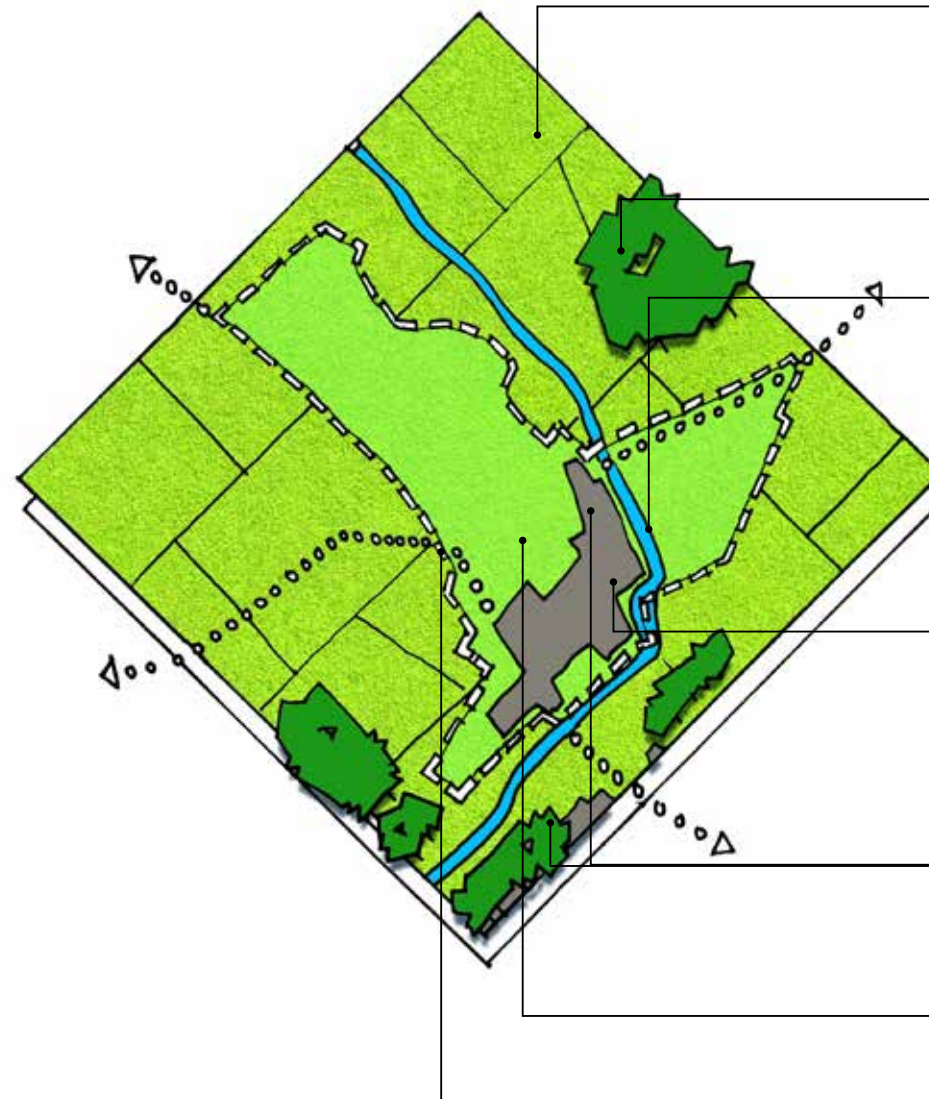

Ickleford is surrounded by arable fields and natural spaces. Safe and accessible corridors within the fields can improve the connectivity of the NP area

Include natural assets in a network of public pathways and rights of way

Consider the rivers, watercourses and waterfronts as part of a network of natural spaces

Maximise road and street network connectivity, particularly if cul-de-sacs are suggested

Make the best use of existing public transport services and improve safe walking and cycling paths that connect all parts of Ickleford

Locate development where the need to travel will be minimised

Limit any significant impacts from and to the development of the highways and transportation network

This code is applicable to the following area types:
(Those areas where it is applicable are highlighted in colour)

A

B

C

D

E

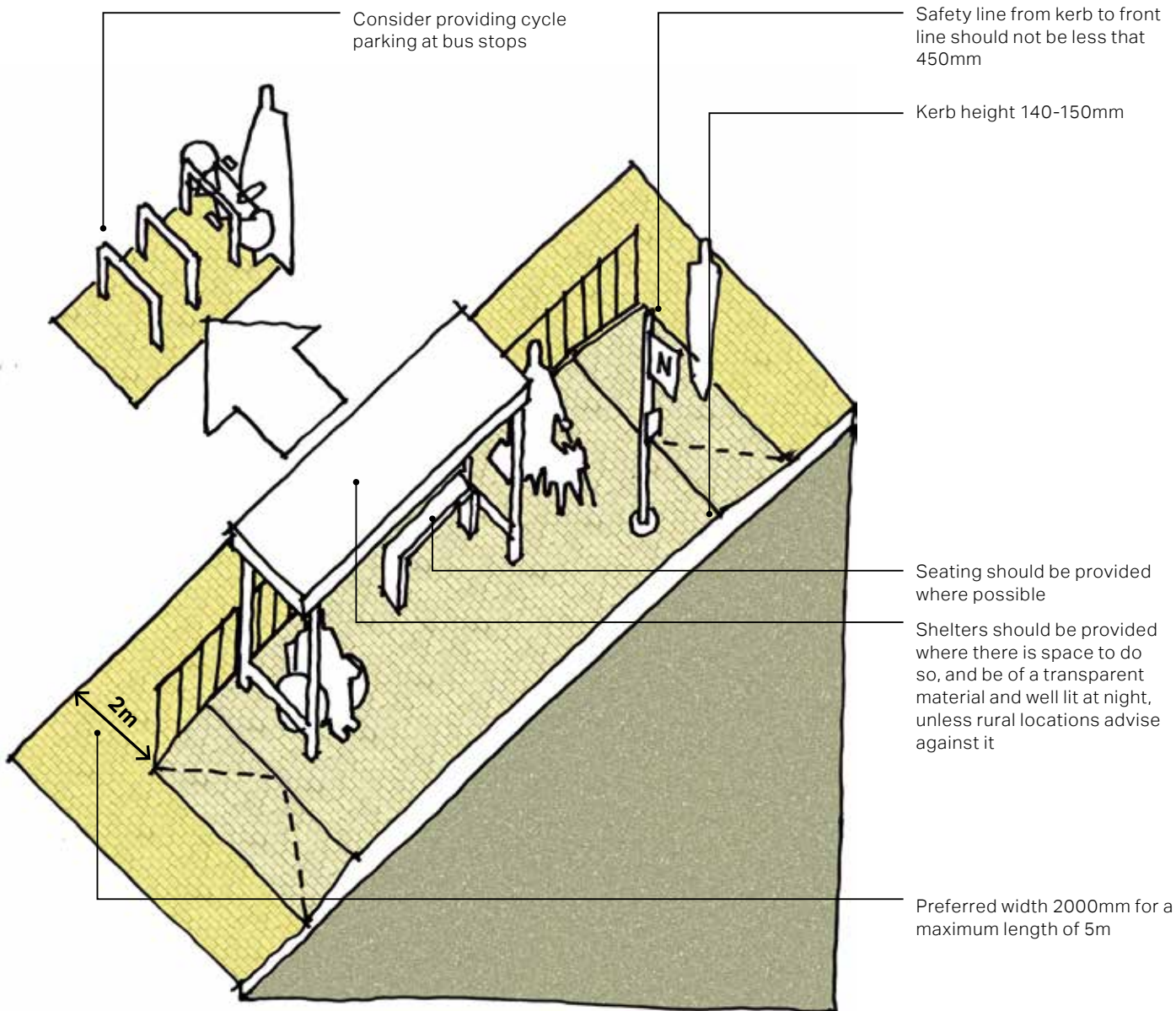

Movement

MO.02 Public transport

Many bus stops have to be placed in locations where footway space is limited but, where space permits, the following guidelines are suggested.

There are two conventional types of bus boarder: full width and half width.

Actions:

- A full width boarder juts out into the carriageway far enough for the bus to avoid parked vehicles, that is by approximately 1800mm.
- A half width boarder, which juts out by between 500mm and 1500mm, is a compromise design that can be used where a full width boarder would unduly delay other traffic or place the bus in or too close to the opposing traffic stream.
- Shelters should be provided where there is space to do so. From the point of view of disabled passengers, particularly wheelchair users, the best location for a shelter is opposite the boarding point.
- For reasons of personal security the bus shelter should be made mainly of transparent material and well lit at night, though use of other materials may be more appropriate in rural areas.
- Seating should be provided where possible.
- Bus stop flags should be fixed as low as possible while remaining visible above road traffic, pedestrians and any other nearby obstacles.
- Consideration should be given to providing cycle parking at bus stops with significant catchment areas. Cycle parking should be designed and located so as not to create a hazard, or impede access for, disabled people.

Movement

MO.03 Wayfinding

Wayfinding

A way of making walking and cycling easier is to ensure that routes are direct as well as memorable.

Actions:

- Create places that have a clear identity and that are easy to navigate.
- Local landmark buildings or distinct building features -such as towers, chimneys, or porches- and clear, direct routes can help with legibility. Clear signage should be placed at key nodes and arrival points to aid orientation.
- Use landscape and feature trees as both wayfinding aids and as elements that provide enclosure and attractiveness to the street. Trees can be a great design tool to mark the access to new developments and distinct parts of an area.

Serial vision

Actions:

- Subtle variations in alignment and small setbacks of buildings can have a powerful effect of discovery and drama when moving through a development.
- This effect can be achieved through delivering schemes that allow free movement from one place to another, movement to the enclosed space of a square or courtyard where people meet, and to the focal point where people go to.
- This process can be described as the interplay between sequences of focal buildings and building features, landmarks and vistas.

This code is applicable to the following area types:
(Those areas where it is applicable are highlighted in colour)

A

B

C

D

E

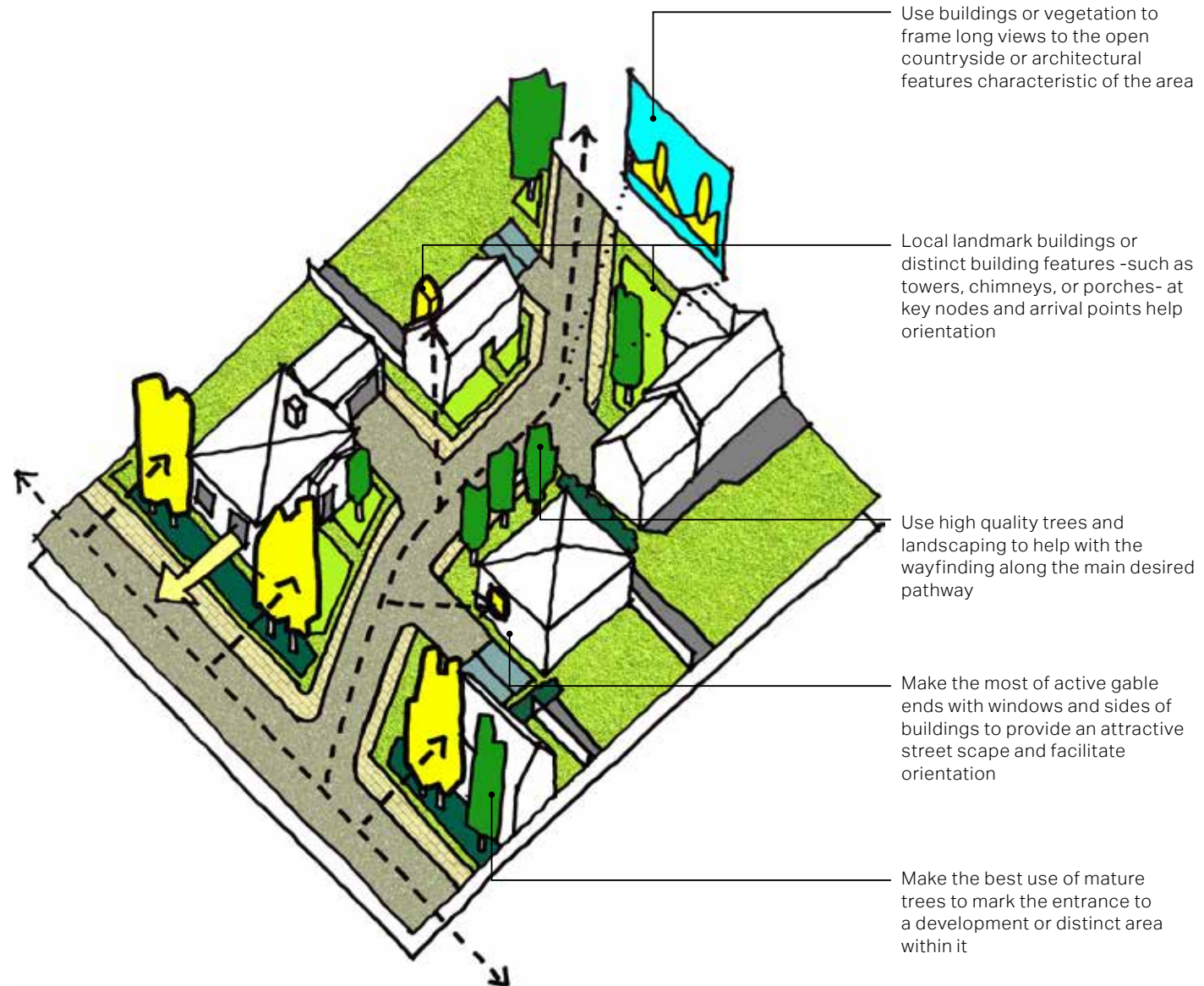

This code is applicable to the following area types:
 (Those areas where it is applicable are highlighted in colour)



Movement

MO.04 Junctions

Spacing of junctions

Generally, the spacing of junctions should be determined by the type and size of urban blocks appropriate for the development. Block size should be based on the need for permeability, and generally tends to become smaller as density and pedestrian activity increases.

Stopping sight distance

The stopping sight distance (SSD) is the distance within which drivers need to be able to see ahead and stop from a given speed. It is calculated from the speed of the vehicle, the time required for a driver to identify a hazard and then begin to brake (the perception–reaction time), and the vehicle’s rate of deceleration. For new streets, the design speed is set by the designer.

The SSD can be a good proxy to estimate block dimensions and minimum spaces between junctions and crossings mid-block, as per the diagrams to the left. Using the SSDs charts (and equations) in the *Manual for the Streets*, blocks 1 to 3 display the minimum widths of blocks based on the desired speed of cars. Blocks 4 to 6 display minimum widths of blocks if they have additional crossings in the middle of them.

Accessibility

Actions:

- Generally, all the development should be suitable for all user types and disabilities.
- Designing inclusive streets for pedestrians requires the designer to fully understand the users and how different disabilities present various design challenges. A tactile/tonal distinction should be made between pedestrian areas and vehicular areas and at crossings /intersections, so that people with visual impairment can distinguish between the two.
- Accessible streets should ensure clear widths and gently sloped gradients wherever possible.

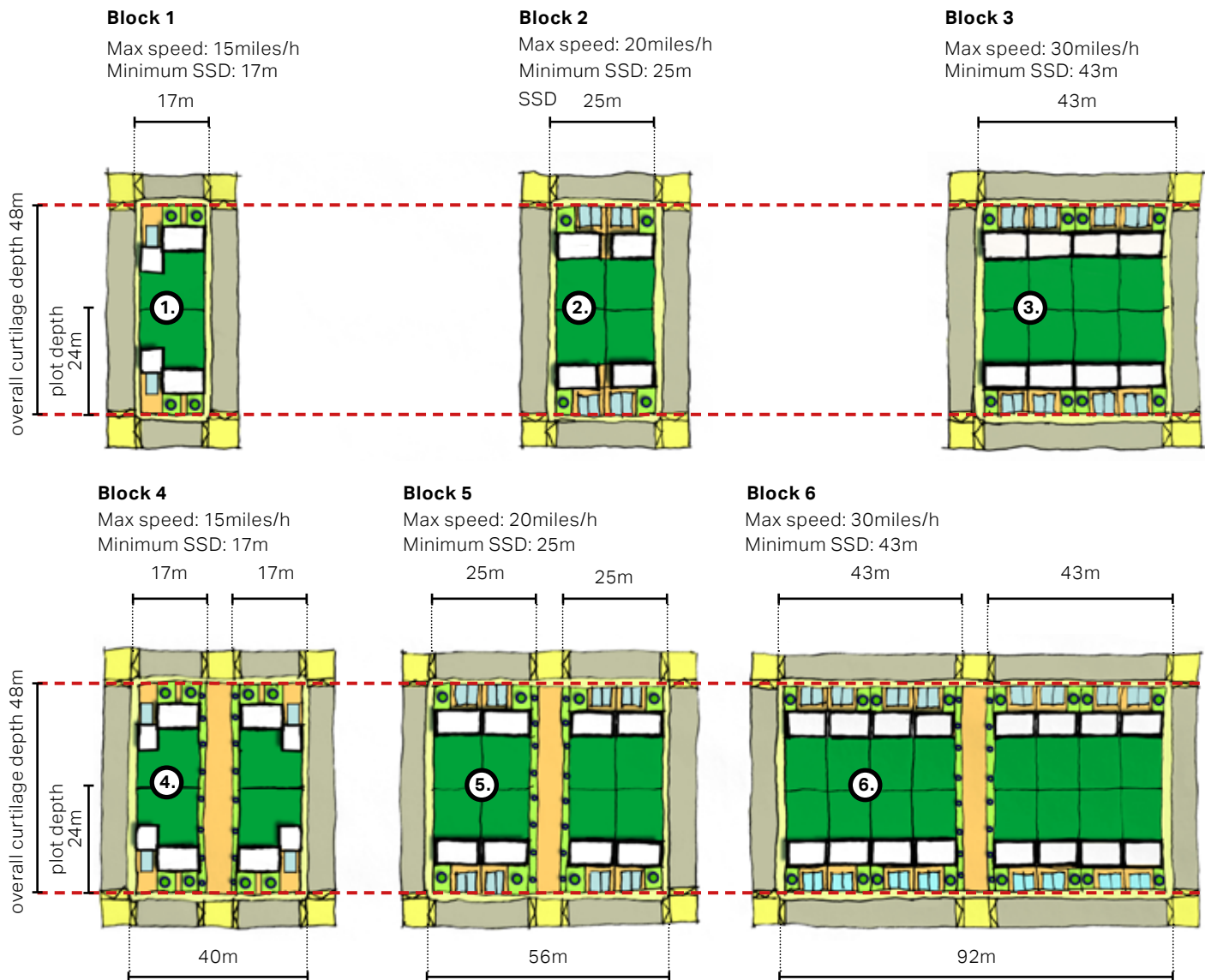

Note: Please note that these distances are recommended minimum distances and that they might be modified and influenced by other design conditions and interests such as topography, landscape conditions, etc.

Movement

MO.05 Inclusive streets

Footway widths

Actions:

- A clear width of 2m allows two wheelchairs to pass one another comfortably. This should be regarded as the minimum under normal circumstances.

Gradients

Actions:

- Recommendations vary somewhat across guidelines but, under normal circumstances, a figure of 2.5 per cent (1 in 40) should be regarded as the maximum acceptable. Where possible, it is preferable to have a crossfall between 1 and 2 per cent.

Surfaces

Actions:

- Uneven surfaces and gaps between paving slabs can cause problems for people using sticks and crutches, visually impaired cane users and wheelchair users. Joints between pavers should be as small as possible.
- When small paving bricks (paviours) are used, care should be taken to ensure that they are evenly laid; any unevenness can cause problems for some wheelchair users and some visually impaired cane users. Cobblestones should not be used.

Colours

Actions:

- Use colour / tonal contrasted marking to identify street furniture, railing or boarding around street works, scaffolding, and tactile paving surfaces. The main purpose of using contrasted marking is to help partially sighted people avoid obstacles that they might walk into or trip over.

This code is applicable to the following area types:
(Those areas where it is applicable are highlighted in colour)

A

B

C

D

E

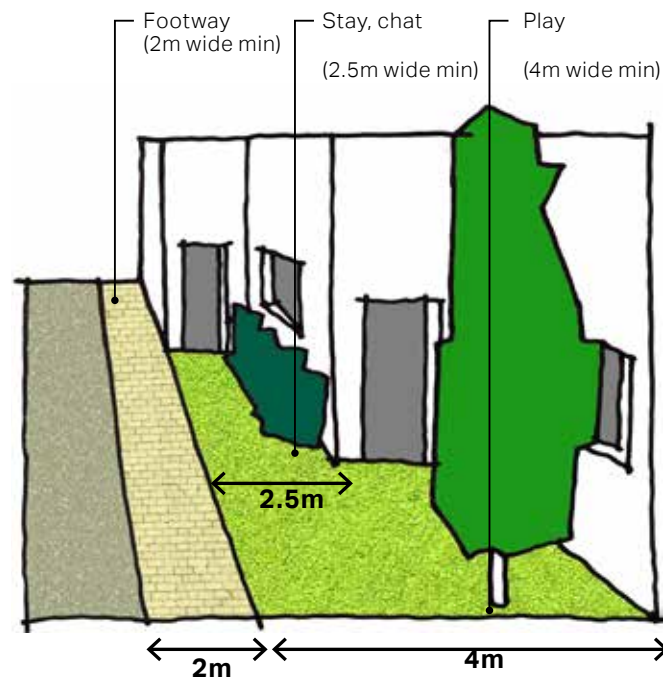
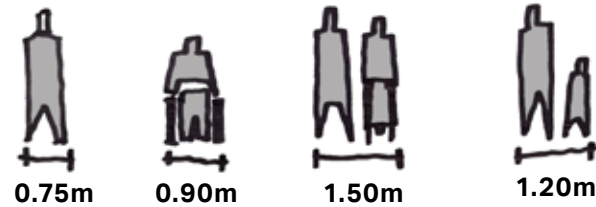

Footway widths

The footway and pedestrian areas provide for a range of functions which can include browsing, pausing, socialising and play

This code is applicable to the following area types:
 (Those areas where it is applicable are highlighted in colour)



On-plot parking on driveway

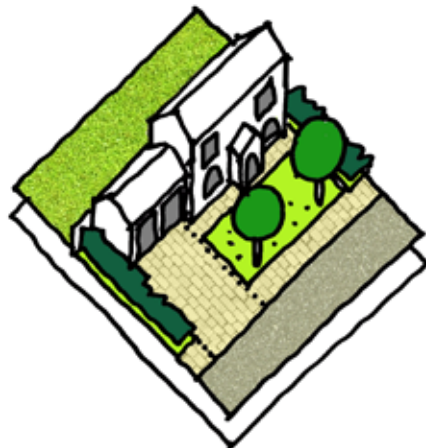

On-plot parking in garage



On-street parking adjacent public open space



Boswell Drive. On-plot parking on driveway



Cedar Avenue. On-plot parking in garage



Chambers Lane. On-street parking should be limited to locations near public open space

Movement

MO.06 Car parking

Car parking design should be safe and should not undermine the quality and amenity of the streets. In residential developments, parking should be provided on plot, either in garages, car ports or on the plot to the side or to the front. Generally, on-street parking should be considered only for visitors and near public open spaces, and kept at a minimum. Generally, parking courtyards and flat-over-garages are not allowed in residential areas.

On-plot parking

Actions:

- On plot parking can be either in garages or car ports and/or on the driveway. If parking is proposed at the driveway, it is preferable to place it at the side of the building to minimize the presence of cars on the street.
- Driveway parking at the front of the building will only be allowed if it is combined with high quality and well designed soft landscaping.

On-plot garages / car ports

Actions:

- Garages should preferably be designed in forms linked to the main building, rather than free-standing structures. In both situations, they should reflect the architectural style of the main building.
- Garages should be in line or recessed from the main building line, and not dominate the street.
- Integrate bicycle parking and/or waste storage into garages.

On-street parking

Actions:

- Provide parking for residents on plot and provide visitor parking on the street adjacent to public open spaces and on other streets only if the width of the road allows for it.
- Visual impacts from visitor parking on the street scene can be ameliorated by the use of high quality landscaping and planting.

Movement

MO.07 Cycle storage

Bicycles

Actions:

- A straightforward way to encourage cycling is to provide secured spaces for bicycles within all new residential developments and publicly available cycle parking racks in the public realm.
- For residential units, covered and secured cycle parking should be provided within the domestic curtilage. The most appropriate location to avoid clutter on the streetscape is to provide space for bicycles within garage sheds or in secure bike storage boxes on the rear gardens.
- Access from the street to rear gardens should be provided via secured gates. Bulky bike storage on front gardens should be avoided.

Refuse bins

With modern requirements for waste separation and recycling, the number of household bins that need to be stored has generally increased. It is important that these are accommodated in ways that allow convenient access, and without increasing street clutter or harming the appearance of new buildings.

Actions:

- The most appropriate location for waste bins to avoid clutter on the streetscape is in rear gardens.
- It is normally advisable to have access to the back garden from the street with a secured door. It is also recommended to have direct exit to the back garden via the kitchen. A paved section on the garden can be located nearby and hold the required bins so they can take the organic waste generated in the kitchen and be taken out to the front of the property for collection.
- There are several solutions to minimise the presence of wheelie bins on the garden, by using screening or planting to conceal them.

This code is applicable to the following area types:
(Those areas where it is applicable are highlighted in colour)

A

B

C

D

E



Provide racking spaces on public open spaces



Provide secured storage space for bikes within the domestic curtilage



Access gate to back gardens, that provides a clear route for refuse bins to be moved from back gardens to the front of the property for collection



Positive example on how to conceal the presence of bins in back gardens

Movement

Storage at the front of the dwelling

Many times, it can be a good idea to provide additional storage at the front of the property. It can be a good place to store bicycles, tools or coats that are likely to have outdoor use.

Incorporating a front windbreak, as part of a projecting porch or as recessed space with a double door, is a good way of minimising heat losses and can easily include the type of storage mentioned before.

Ideally, this area could also provide the space for meters boxes, liberating the facade from clutter.

Note: for further detail on the typologies to the left, please refer to design code *HO.01 Space Standards*. For further detail on how to avoid clutter of services and pipework on facades please refer to design code *ID.01 Local Character*.

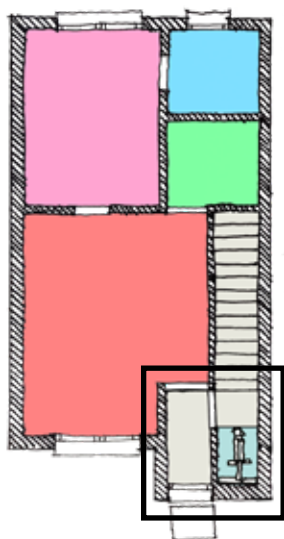

Projecting porch with storage and windbreak (double door)



Windbreak (double door) and storage with opportunity for integrated meter box

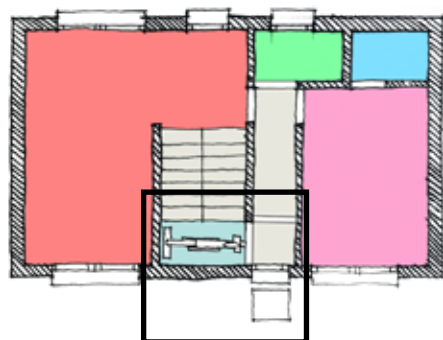

Windbreak (double door) and storage under the stairs

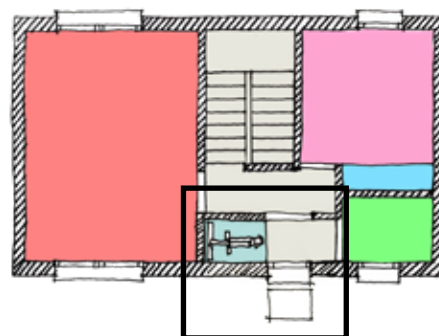

Windbreak (double door) and storage with auxiliary toilet



Example of a recessed porch, hiding the meter box and providing a small storage space, although not providing a windbreak.

Refer to: Slingsby Place (Sheffield). Proctor and Matthews.

Nature

NA.01 Green Belt

Green Belt

New development on the Green Belt is generally not allowed. Inappropriate development, including the construction of new buildings, is considered harmful and will be contested unless very special circumstances exist which outweigh the harm.

The only development allowed in the Green Belt is:

- Extension and alteration to buildings and replacement of buildings.
- Re-use of buildings.
- Outdoor sport and recreation.
- Infilling or redevelopment on previously developed land.

This design code gives guidance on how to best approach the refurbishment of agricultural properties in the area.

This code is applicable to the following area types:
(Those areas where it is applicable are highlighted in colour)

A

B

C

D

E

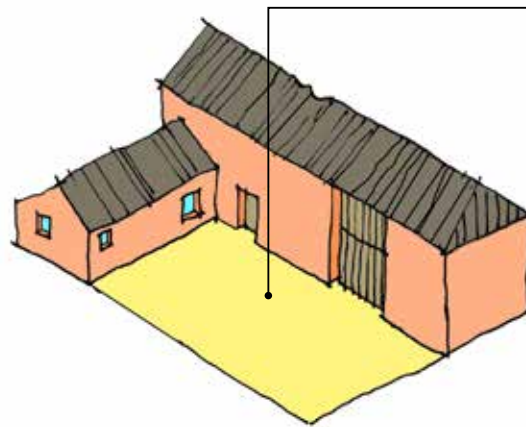

The form and appearance of agricultural buildings reflects their setting and function. Conversions of this kind of buildings should not become domestic in appearance and still reflect the historic character of the building, derived from its original use

Agricultural buildings

Agricultural buildings were originally designed for a specific purpose, illustrating historical agricultural processes. This usually results in a specific appearance and layout. Understanding the setting, function and form of the buildings will guide how to plan alterations to the exterior and interior

Avoid domesticity

When converting an agricultural building it is of paramount importance that the building does not become domestic in appearance and retains its agricultural character regardless of its new use. Essentially, it should not look like a house.

Actions:

- Avoid domestic add-ons such as chimneys, dormer windows, conservatories and porches. Avoid elements that add visual clutter such as satellite dishes, domestic external lighting, hanging baskets. Avoid using domestic window or door styles and adding buildings such as sheds within the curtilage.
- Retain characteristic features of historic working buildings such as the original openings, which should not be partially or completely filled in. Retain ventilation slots (often patterned) and any use-specific historic additions.

Windows & doors

Agricultural buildings are characterised by long façades with few asymmetrical openings.

Actions:

- New openings should be kept to a minimum. They should not be planned in a regular or symmetrical pattern, as this is overly domestic. They should replicate existing proportions, construction and typical reveal.
- Reduce the visual impact of new frames as much as possible, avoiding excessive transom and mullions and general window divisions, opting for simple and slender frames and glazing. They should also be set back into a reveal.

Large openings

Actions:

A key feature of agricultural buildings are big openings. This includes threshing, cart, and wagon doors. These large openings should not be partially or completely blocked or filled in, and should be retained.

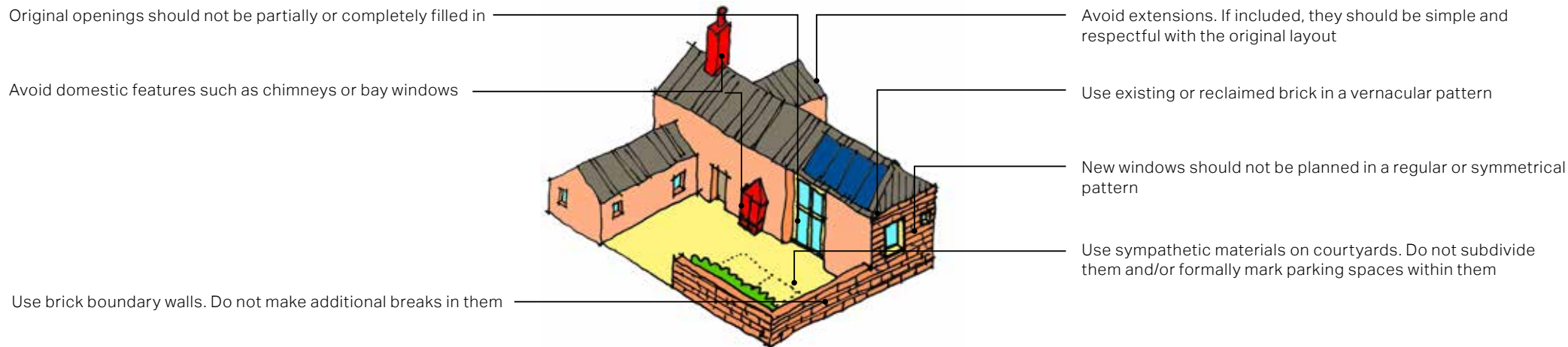

Roofs

Actions:

- Avoid domestic features such as dormer windows. If roof lights are used, they should be used sparingly and sited discreetly so as to not become a feature in the landscape.
- Avoid accretion of visual clutter including ridge and roof vents.
- Local roofing materials include thatch, clay tiles and slate. These should be retained and re-used wherever possible.
- If required, solar PV panels should not be placed in the main roof gable or façade if other locations are available which would not significantly hinder the performance of the PV cells. In all cases PV panels should integrate with the overall pitch, materials and feel of the roof.

Materials

Actions:

- Existing brickwork should be reused or reclaimed. Give consideration to the material source and matching the colour, texture, size and bond of the existing brickwork and use a lime-based mortar mix.

- Historic fabric should be repaired where necessary. Timber-framing should be repaired replicating historic joint methods. Replacement of weatherboarding is should match the scale of the existing. Exposed historic timbers should not be painted or stained.

Extensions

Actions:

- It is usually not appropriate to extend an agricultural buildings or add new buildings in the curtilage. If they are included, extensions or additions should generally be simple, unobtrusive, and respect the plan-form of the building and group layout.

Rural setting

Actions:

- Courtyards should be surfaced in a material that reflects their rural setting. Farmyards should remain open and not be divided by fences or walls. Parking spaces should not be formally marked out.
- Where the use of landscaping and boundary treatments can be justified, design cues should be taken from existing traditional features and will typically consist of metal agricultural or timber post and rail fencing, low brick or stone

walls and native hedgerows.

- Boundary brick walls should be left intact, and not chopped through or reduced for access or to create visual splays.

Disused rural buildings

Proposed development outside the settlement boundary for the re-use and/or adaptation of redundant or disused rural buildings is generally acceptable when buildings are no longer viable in their current use.

Actions:

- Assess the viability of re-use. The building should be capable of conversion without significant rebuild or alteration.
- Any proposed extension(s) or alterations should be proportionate to the size, scale, mass and footprint of the original building and be situated within the original curtilage.
- In general, all development proposals for the re-use of redundant rural buildings should result in the enhancement of the immediate setting.

Nature

NA.02 Green networks

Green networks

Green networks, corridors and linkages are widely seen as a key mechanism for reversing the effects of fragmentation on biodiversity. They also deliver a range of other social and environmental benefits, including enhancement of local landscape character, and greater opportunities for public access and recreational use.

Actions:

- Provide a connected network of private and public green spaces that includes generous and vegetated back and front gardens, public green spaces, fields and natural open spaces.

This code is applicable to the following area types:
(Those areas where it is applicable are highlighted in colour)

A

B

C

D

E

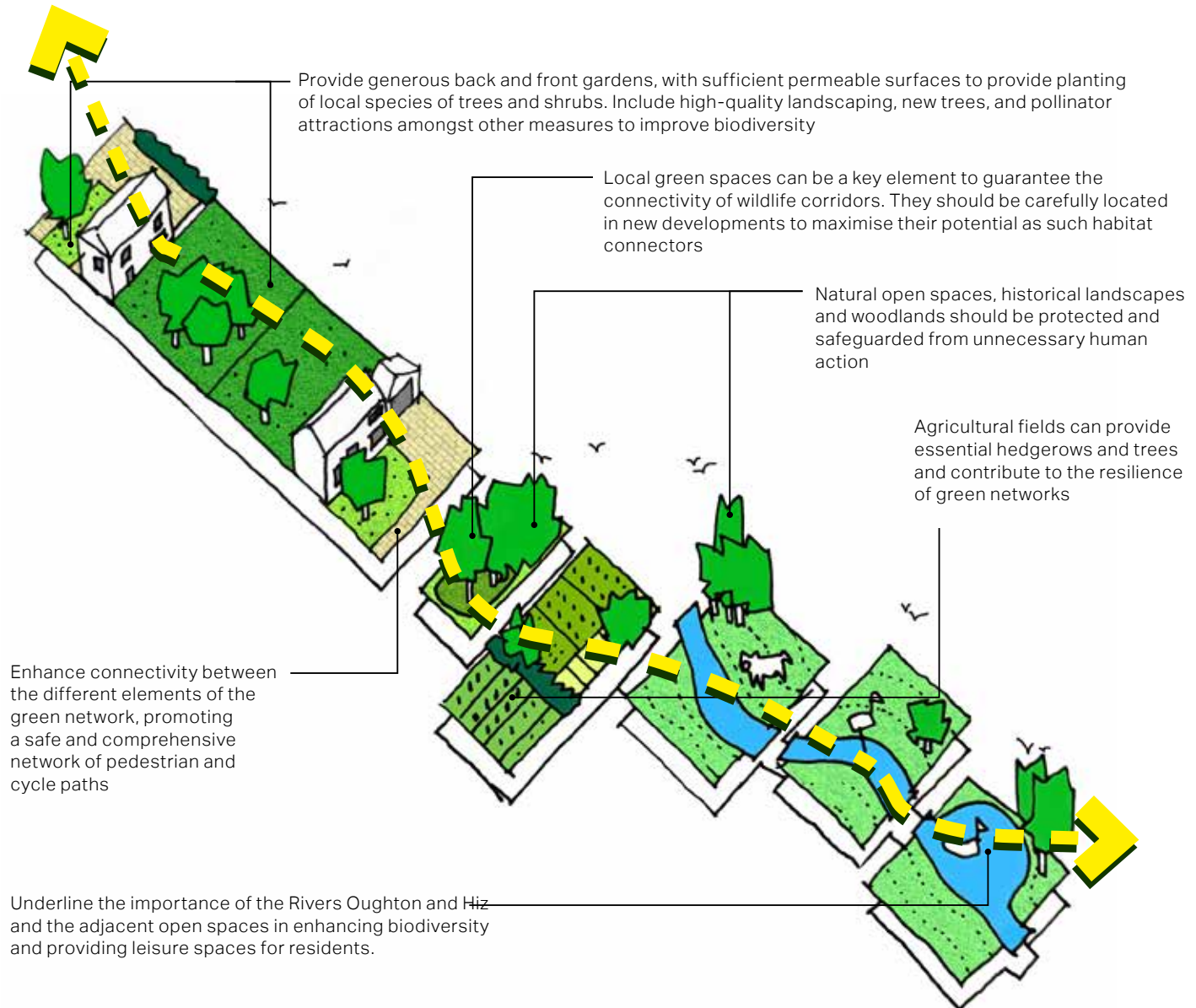

This code is applicable to the following area types:
 (Those areas where it is applicable are highlighted in colour)

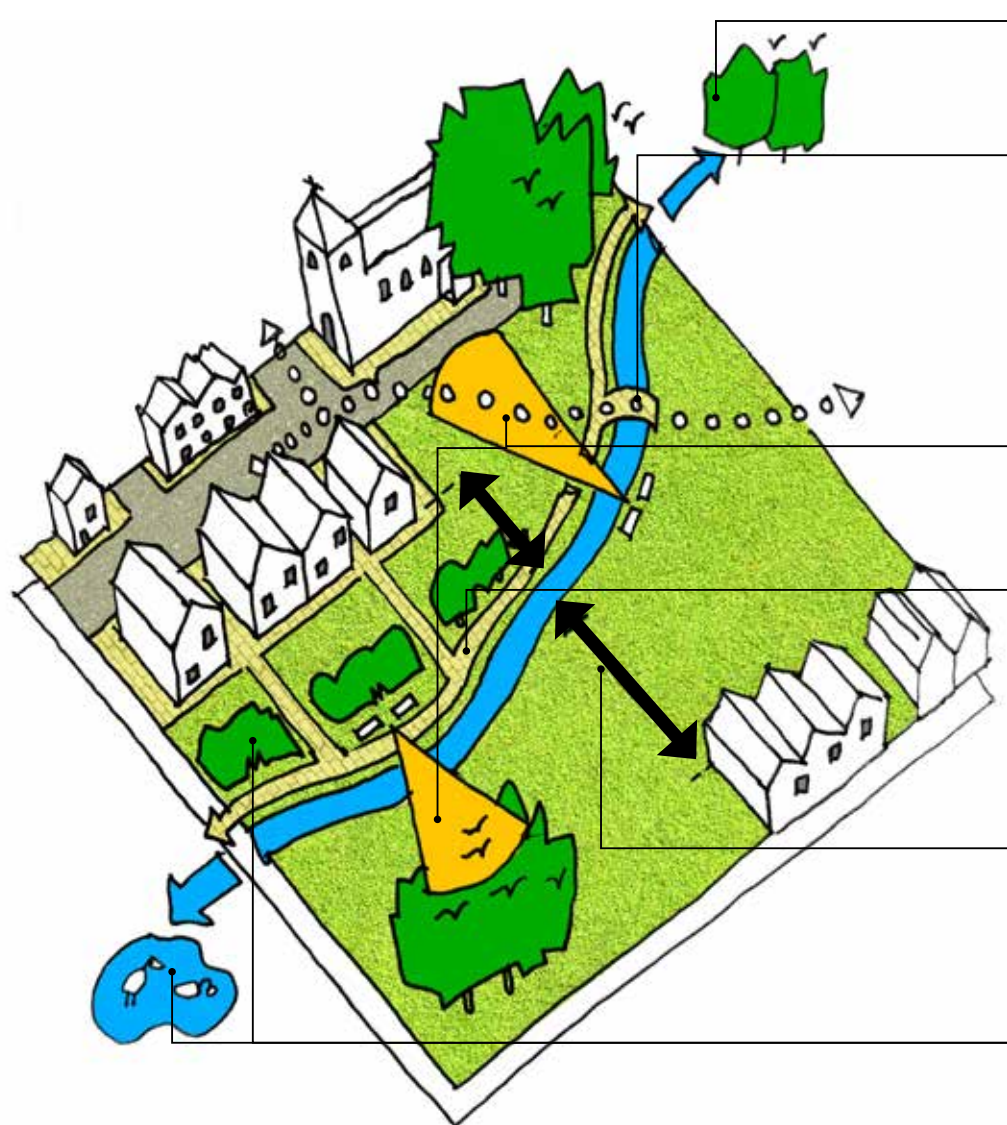

Promote and maintain semi-natural habitats along the river

Consider the need for bridges as part of an integrated network of paths

Consider views to and from built and natural assets to prioritise which spaces should be improved more urgently

Improve the condition of paths along the rivers, to ameliorate their accessibility and the reach of the amenity to residents

Maintain gaps and buffers to the river and prevent unnecessary development

Promote new planting and encourage local biodiversity

Nature

NA.03 Design with water

Blue networks

Ickleford is home to the confluence of the River Oughton, which flows along the southwestern edge of the village, and the River Hiz, flowing along its northeastern edge - adding to the village's character whilst providing a valuable piece of natural amenity to local residents.

Actions:

- The Rivers Oughton and Hiz constitute the limits of the Neighbourhood Area to the south and southeast acting as natural boundaries. The preservation of the existing gaps between the settlements of Ickleford and Hitchin, that fall outside of the current Neighbourhood Plan Area, is key to maintaining the integrity of the natural system that those rivers constitute. It is of utmost importance that both Councils acknowledge and work together to protect those gaps from the pressure of development.
- Improve the condition of paths along the rivers, to ameliorate their accessibility and the reach of the amenity to residents, although the rare Chalk Stream ecosystem means that access to the river itself requires careful management.
- To protect the rare Chalk Streams ecosystem, relevant information must be available at points where people might access the rivers.
- Consider the need for bridges and assess the best location for them. Promote the creation of new and retention of existing ditches connecting to the river, keeping existing ones free of litter and obstacles.
- Avoid damage to the riverbanks as a result of agricultural, industrial or other practices.
- Promoting and encouraging biodiversity of locally native species, and semi-natural habitats along the river, but only after getting guidance and advice from specialists (e.g the Herts and Middlesex Wildlife Trust), who have the knowledge about the flora and fauna of Chalk Streams

Nature

NA.04 SuDS

Sustainable Urban Drainage Systems

Sustainable urban drainage systems or SuDS are designed to reduce the rate of rainwater run-off from new development, mitigating the risk of flooding elsewhere whilst delivering benefits for biodiversity, water quality and amenity. Ideally water needs to be captured for use on site for irrigation and non-potable uses. Where this is not possible schemes need to follow the hierarchy set out as follows in decreasing preference of measures, by which water is:

- Allowed to infiltrate into the ground.
- Attenuated for gradual release to a water body.
- Released into a water sewer, highway drain, or another drainage system.
- Released into a combined sewer.

Actions:

- The approach to each site will depend on its density, the position of watercourses, the ground conditions including permeability, contamination and the sensitivity of groundwater receptors.
- It is particularly important that rain run-off does not drain directly into chalk rivers.
- SuDS need to be considered early in the design process to ensure efficient integration with other aspects of design such as public open space, biodiversity provision, and highways so as to minimise the land needed.
- Multi-functional SuDS need to be prioritised allowing for attenuation features which can also be used for biodiversity and recreation.

This code is applicable to the following area types:
(Those areas where it is applicable are highlighted in colour)

A

B

C

D

E

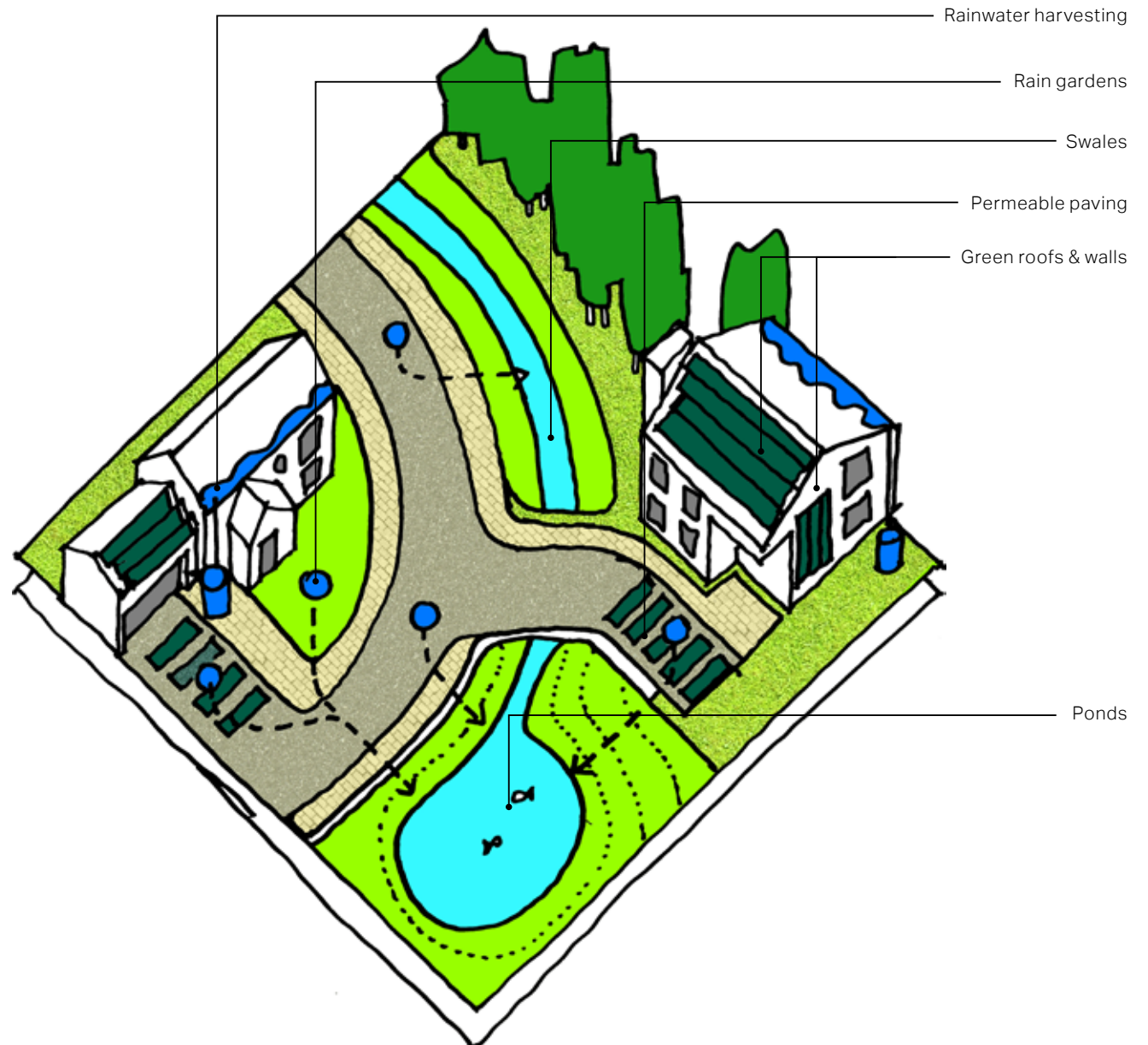

This code is applicable to the following area types:
 (Those areas where it is applicable are highlighted in colour)



Road paving

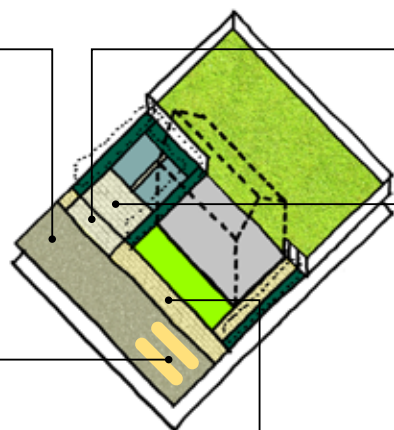

Interrupted footways over driveways



Uninterrupted footways over driveways



Crossings



Footways



Driveways

Nature

Surface treatments

Paved areas and surface treatments are a major element within most developments, and their design has a significant impact on the overall appearance, quality and success of a scheme.

The choice of footway and its degree of permeability to the soil below is key in successful surface water management. Paving materials should be robust, aesthetically attractive and with good weathering properties to make a sustainable and attractive street scape.

Road paving

Block paving is generally recommended as road surface material that can permeate to the soil below, over asphalt. In all cases, large unbroken areas of a particular surface material should be avoided, and areas can be broken up successfully using materials of a similar colour but with different textures. Asphalt with added porosity can be a successful alternative.

Footways

High quality materials such as stone, brick or block paving can all constitute good options for footways. Asphalt footways are generally the most economical option but are monotonous and make wayfinding more difficult, repairs patches create dissonant streetscapes, in addition to their reduced permeability. The laying pattern and materials used can make a significant contribution to the overall appearance, quality and success of a scheme.

Driveways

Permeable paving options can be successfully applied to driveways to maximise the accumulation effect of front garden greenery as a way to enhance the street landscape. Prioritise bigger portions of green within the footway rather than a very granular paving pattern.

Footways over driveways

Footway patterns should prevail over the driveway access. To guarantee a coherent street and a continuous walkable path, kerbs should not invade the footway.

Sustainable urban drainage systems

Any proposed hard surfacing design will need to take into consideration the need for an underlying system to deal with water run-off, as any hard landscaping will impact the management water run off and affect the capacity of the drainage system.

Nature

NA.05 Net-gain

Measuring biodiversity gains

Measurement of pre and post-construction biodiversity levels will be based on DEFRA's 'Biodiversity Metric 3.0' (see diagram to the left).

Compensation for biodiversity loss

The interpretation of Biodiversity Net Gain includes the option for off-site 'compensation', if biodiversity losses are unavoidable in accordance with DEFRA's mitigation hierarchy. Certain 'irreplaceable habitats' are not included in this option.

Actions:

- Local decision makers will need to agree biodiversity net gain plans with developers, as well as specify by a condition, planning obligation or conservation covenant, how long the developer should maintain the habitat enhancement, with a minimum requirement of 30 years.
- If off-site compensation is agreed, as a last resort, in that plan, local authorities will review developers' plans to ensure they deliver compensation through local habitat creation projects.
- If suitable local projects are unavailable, the government indicates nationally strategic habitats can be invested in.

This code is applicable to the following area types:
(Those areas where it is applicable are highlighted in colour)



Measuring biodiversity gains:

1. Baseline biodiversity score

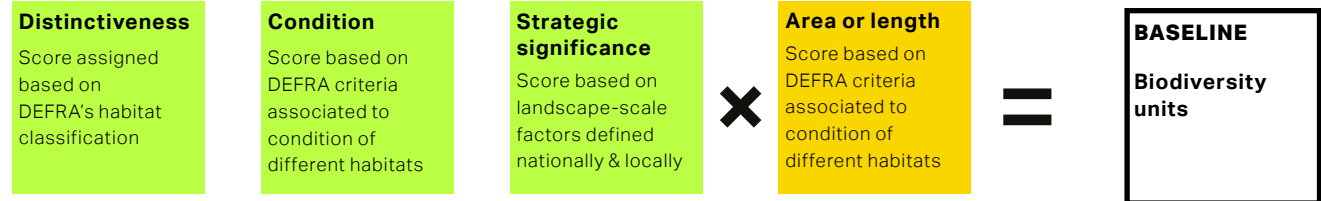

2. Post-development biodiversity score



3. Biodiversity net-gain

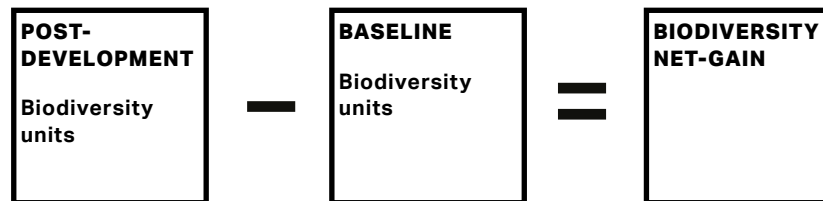

This code is applicable to the following area types:
(Those areas where it is applicable are highlighted in colour)



Create habitats for wildlife, such as bird and bee boxes



Incorporate water and wildlife friendly ponds in gardens



Allotments can have positive impact on the landscape and community

Nature

NA.06 Biodiversity

Back and front gardens, together with public green open spaces and surrounding fields play a key role in supporting biodiversity in built-up areas. They have the potential to create habitat mosaics and enable wildlife corridors, often linking up with parks, tracks, rivers, churchyards and hedgerows. Users can follow these steps to foster wildlife and habitat creation in their community.

Actions:

- Reduce or eliminate use of chemicals in gardens, use companion planting and physical removal to combat pests such as aphids, slugs and sawfly.
- Create habitats for wildlife; bee-boxes, hedgehog homes, log and stone piles for invertebrates, toads and slow worms who will also inhabit a compost heap.
- Plant late, mid-season and early blooming nectar rich flowers to attract pollinators and beneficial insects all year round.
- Make a pond, keep it ice free in winter by floating a ball on the top and ensure that it is safe for children.
- Feed birds through the winter and supply nesting boxes.
- Allotments can be another green structuring element that improves natural habitats, consider the need for allotment plot allocation when planning a new development.

Nature

NA.07 Street planting

Flower beds, bushes and shrubs

- Normally planted within the curtilage boundary, ornamental species add interest and colour to their surroundings and become an identity and expressive feature of each dwelling. The use of native species should be favoured to avoid the impact of invasive species on the biodiversity of local habitat.

Hedges

- Hedgerows are normally used to mark property limits, they can also be planted in front of bare boundary walls to ease their visual presence. They can be used to conceal on-plot car parking and driveways within curtilages. They can also be used as protective barriers on gable ends facing windows onto the street.

Trees

- Trees can normally be used to mark reference points and as feature elements in the streetscape. When planted at intersections and key locations, they improve privacy whilst enhancing the wayfinding and distinctiveness of the area. These tend to be within property curtilages.
- Trees should also be present in any public open space, green or play area to generate environmental and wildlife benefits.

Planting standards

- The British Standard 5837: 2012 'Trees in relation to construction- Recommendations' should be the reference document when considering new and existing trees on proposed development sites.

Actions:

- Existing trees should be retained as much as possible.
- The success of tree planting is more likely to be achieved when it has been carefully planned to work in conjunction with all parts of the new development, parking, buildings, street lights, etc.

This code is applicable to the following area types:
(Those areas where it is applicable are highlighted in colour)

A

B

C

D

E

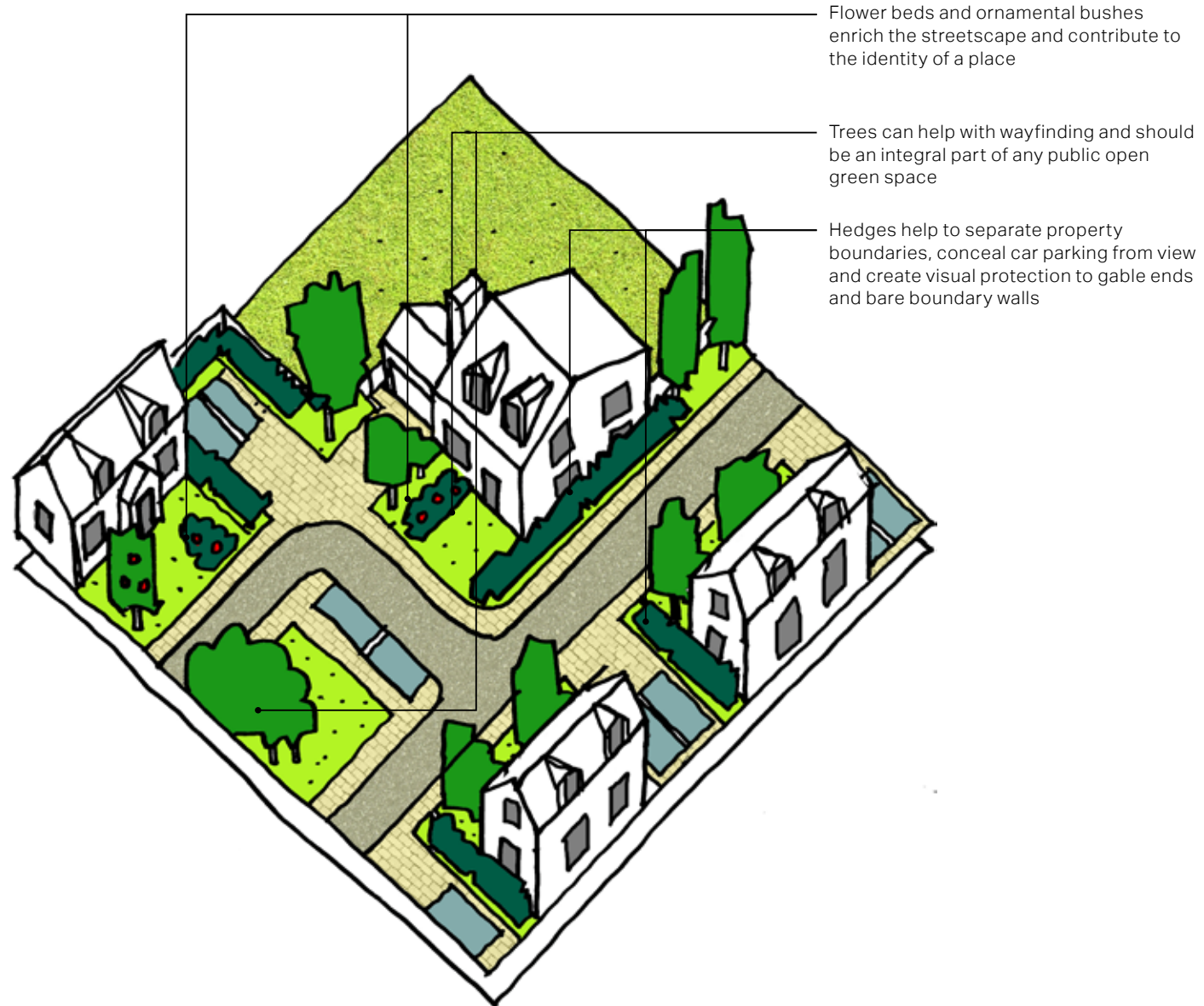

This code is applicable to the following area types:
(Those areas where it is applicable are highlighted in colour)

A

B

C

D

E

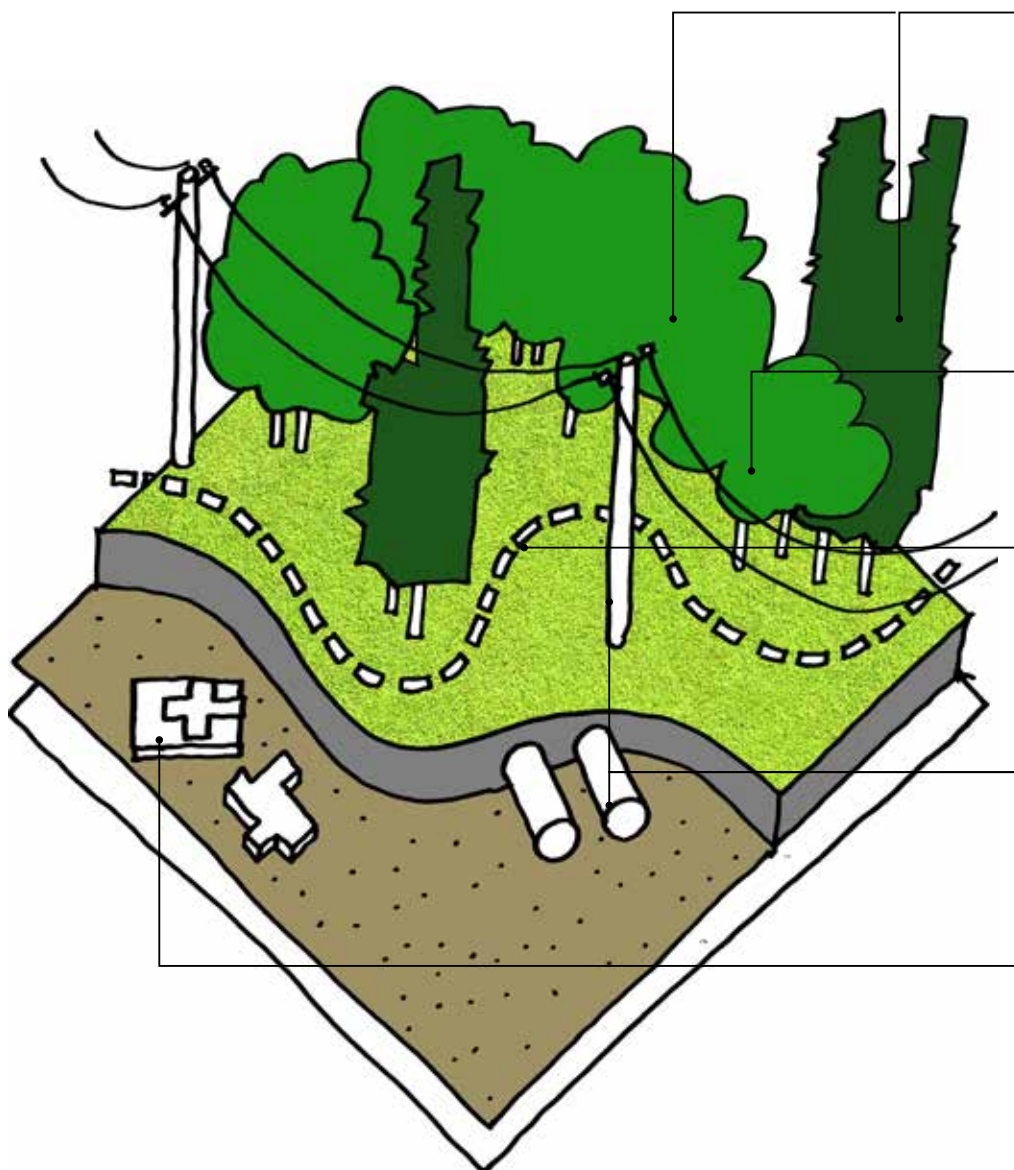

Provide a mix of native species. Trees should be UK sourced and grown, and the seed origin should be fully traceable

Plant small groups of the same species together – this will help reduce competition between different species as they grow

Plant in wavy lines and varying spacing between trees. This will balance more densely planted sections with open areas for a natural look and feel

Consider under or above ground services when selecting the location for new planting to avoid damage to the existing infrastructure

Consider the location when proposing new planting. Archaeological sites, sites with rare or protected species, grassland that has never been ploughed, wetlands and heathland habitats should not be planted

Nature

NA.08 New woodland

Planting a single tree has benefits for people, wildlife and the environment. Those benefits vastly increase when planting a whole woodland. New woodlands can help increase biodiversity, provide shelter, prevent soil erosion, and reduce flooding.

Actions:

- Encourage the planting of native broadleaved trees. Trees should be UK sourced and grown, and the seed origin should be fully traceable.

Location:

- Consider the planting location carefully. Archaeological sites, sites with rare or protected species, grassland that has never been ploughed, wetlands and heathland habitats should not be planted. Select tree species that are suitable for the soil conditions of the area.
- Be aware of any under or above ground services and design planting accordingly. Provide sufficient buffer to existing infrastructure.
- Consider final size and spread of the trees and the use of the site as the trees grow. Avoid planting under existing trees, as shade and lack of water will seriously restrict growth. Allow plenty of distance from existing hedges as they could swamp the growth of new trees.

Species:

- If the area to plant is large, consider using a mix of native species. UK woods are under pressure from pollution, climate change, pests and diseases. Including a broad range of native tree species will make the new wood more resilient to these pressures and attract different species of wildlife.

Spacing:

- Plant in wavy lines and varying spacing between trees. This will balance more densely planted sections with open areas for a natural look and feel.

Built form

BF.01 Density

Density is the key indicator for how compact a development or place will be and how intensively it will be developed. Different density measures result in more compact or more open development, and therefore have a huge impact on the character of a place.

This section identifies the density ranges of exemplar locations within each area type, to understand how local variations in density result in different identities within the neighbourhood plan area.

Density in this section is measured in dwellings per hectare (dw/ha).

These density ranges can be used as reference for new developments, to facilitate the assessment of the level of compactness and the degree of built areas vs open spaces required in relation to the desired resulting character.

This code is applicable to the following area types:
(Those areas where it is applicable are highlighted in colour)

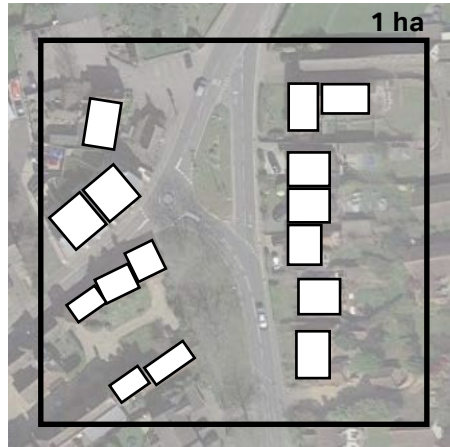

A Historic core
Residential density: 15 dw/ha

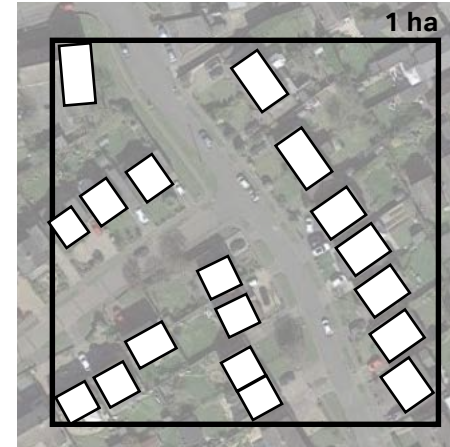

B Settlement
Residential density: 20 dw/ha



C Rural countryside
Residential density: 0 dw/ha

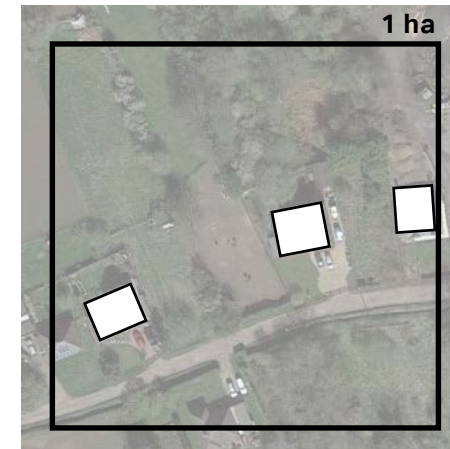

D Green Belt
Residential density: 0-5 dw/ha

Density in new developments should take into consideration the density ranges of the surrounding areas, and suggest a density measure that is appropriate to them.

In every case, density measures over 20 dw/ha should be strongly justified.

E New development
Max residential density: 20 dw/ha

This code is applicable to the following area types:
 (Those areas where it is applicable are highlighted in colour)



A Primarily, detached houses in deep narrow plots



B Primarily, detached and semi detached houses and some detached bungalows.



B Rarely, terraced houses that look like small flat buildings or flat buildings as part of retirement homes.



C No residential properties have been developed in this area.



D Primarily, farms and detached bungalows.

Types proposed in new developments should take into consideration the typologies of surrounding areas, being considerate with building types in the vicinity.

Ickleford's built character ranges from the historic houses in the centre to the denser semi-detached suburbs surrounding it and the rural properties peppered in the Green Belt.

E New development

Built form

BF.02 Types and forms

Housing type refers to the size, purpose and arrangement of housing. Residences constitute the majority of the buildings in an area, and they have a huge impact on the character of a place.

The following section identifies the most frequent housing types in each of the character areas.

These types can be used as reference for new developments, to assess the appropriateness of suggested types in relation to the existing types in the neighbourhood plan area.

Built form

BF.03 Height

The following section identifies the height ranges for buildings in the neighbourhood plan area.

These typical heights can be used as reference for new developments, to assess the appropriateness of suggested types in relation to the existing types in the neighbourhood plan area.

This code is applicable to the following area types:
 (Those areas where it is applicable are highlighted in colour)



A Historic core
 Max residential storeys: 2



B Settlement
 Max residential storeys: 2



B Settlement
 Some rare examples of 3 storey dwellings.



C Rural countryside
 Max residential storeys: n/a



D Green Belt
 Max residential storeys: 1 + pitch

Most residential buildings tend to be 2 storeys across the built area, buildings in the Green Belt tend to be of a lower profile.

The bulk of development should not grow over two storeys. In some cases 3 storey buildings could be justifiable. They need to be carefully designed as they have the potential to significantly impact the built character of Ickleford.

E New development

This code is applicable to the following area types:
(Those areas where it is applicable are highlighted in colour)

A

B

C

D

E

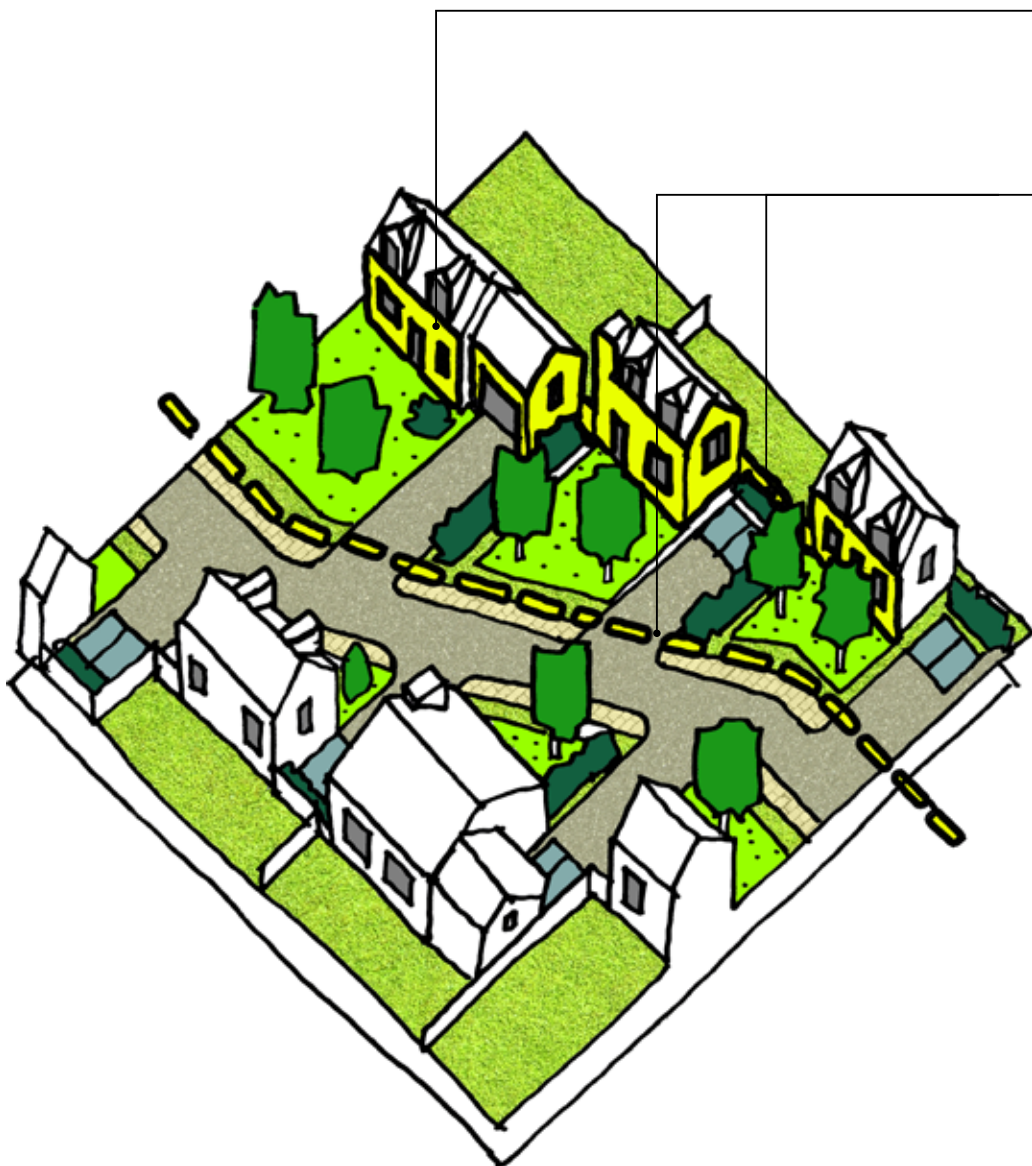

The building line should have subtle variations in the form of recesses and protrusions but should generally form a unified whole

Boundary walls and treatments should reinforce the sense of continuity of the building line and help define the street

Built form

BF.04 Building line

Building line

The way buildings sit in relation to the street can affect the feel of a development.

Actions:

- The building line should have subtle variations in the form of recesses and protrusions but should generally form a unified whole.
- Boundary treatments should reinforce the sense of continuity of the building line and help define the street, appropriate to the rural character of the area.
- Boundary treatments should not impair natural surveillance.

Setbacks

A setback is the distance between the back of the footway and the building line. The size of the setback contributes to the overall character and sense of enclosure along a street.

Actions:

- A coherent street frontage should be achieved by coordinating the setback between buildings and the street. Large differences in setbacks for adjacent properties should be discouraged as they do not contribute to the overall streetscape or the cohesiveness of a place.

Identity

ID.01 Local character

Roof profile & materials

Creating variety in the roof line is a significant aspect of designing attractive places. There are certain elements that serve as guidelines in achieving a good variety of roofs:

- The scale of the roof should always be in proportion with the dimensions of the building itself.
- Monotonous building elevations should be avoided, with subtle changes in roof line being promoted during the design process.
- Local traditional roof detailing elements should be considered and implemented where possible.
- Dormers can be used as a design element to add variety and interest to roofs.
- The predominant material used for roofing is ceramic tile and natural slate, thatched roofs are also traditional. Traditional pitches tend to have a considerable slope.

Wall materials

- Render: rendering and stucco over brick can be found in the area. The local rendering tones are white, ochre, pink and light pastels.
- Brick: Locally, the clays are predominantly rich hues of reds and orange, although from the 18th century a white brick (gaults, etc) and a more yellow London stock was widely used in North Hertfordshire. New development using brick should use a hue that is specific to Ickleford.
- Wooden framing: Wooden frames are used in historic buildings of medieval origin, exposed in many cases and infilled with painted or rendered brick.
- Weatherboarding: once a popular form of cladding used from the 18th century, often for agricultural, cottage and mill buildings, it has recently been used in Ickleford in parts of the post-war suburbs.

This code is applicable to the following area types:
(Those areas where it is applicable are highlighted in colour)



Laurel Way. Image above shows positive examples of roofscape articulations



Arlesey Road. Images above show positive examples of roofscape articulations

This code is applicable to the following area types:
(Those areas where it is applicable are highlighted in colour)



Exposed timber frame with painted brick infill and ceramic tile roofs



Brick facades and slate tiled roofs

Images above show typical wall materials in the area



Images above show typical windows and openings in the area

Identity

Windows & openings

Windows are the 'eyes' of a building and are crucial to its character.

Actions:

- A limited range of traditional window patterns are characteristic of traditional houses in the area and provide appropriate models where a period effect is sought or required.
- Where possible, timber windows should be selected over uPVC alternatives; they can allow a finer profile to be achieved and if they are maintained properly they tend to be more durable.
- Aluminium windows can also offer a much greater range of design possibilities than uPVC alternatives, however these should not be considered as best option when choosing what material windows are made from.
- It is important that for good internal lighting the default position is for large windows on new development.
- In general traditional styled windows look best when painted white; although other colours are welcomed as they add interest to the street scene. If the timber weatherboarding is painted in darker colour (grey or black) windows could also be coloured like the rendering of the building to blend in.
- Cills and lintels frame a window and they should be designed with care. Timber lintels are the simplest form, characteristic of vernacular construction in timber-frame or brick areas.
- Ground floor windows can be larger and deeper than upper floor windows, as they add more animation to the streetscape.
- Corner windows are encouraged, they add architectural interest to the building and have a positive impact on the streetscape.

Identity

Special features

- It is important that the detailing and architectural elements used in new developments are of a high quality and reinforce the local character of Ickleford.
- Architectural detailing shall typically display elements that equate to those on existing traditional buildings which provide interest, scale and texture to form and elevations.

Dormers & bay-windows

- A dormer is a roofed structure, often containing a window, that projects vertically beyond the plane of a pitched roof. Dormer windows are a frequent feature in Ickleford.
- Bay-windows are frequently displayed as part of the dwelling in Ickleford and can be used as local feature elements that add interest to facades.

Porches

- As covered areas adjoining an entrance to a building and usually having a separate roof, they traditionally provide a wind-break and additional buffer to separate the living areas from the weather outside.

Chimneys

- Traditionally, buildings display simply-shaped brick chimneys. New buildings can make use of accent and feature elements such as chimneys to generate visual interest in the roof line and the streetscape.

This code is applicable to the following area types:
(Those areas where it is applicable are highlighted in colour)

A

B

C

D

E



Images above show special architectural features in the area, such as dormers, bay-windows, porches and chimneys

This code is applicable to the following area types:
 (Those areas where it is applicable are highlighted in colour)



Poorly located meter boxes, their presence clutters front elevations



Porches / entries can conceal the presence of meter boxes



Positive example of drainage channel as demarcation of thresholds of water run-off from and to dwellings



Use clean lines and sympathetic colours for gutters and downpipes



Services

Actions:

- Design shared common trenches for service and drainage runs to minimise disturbance to buildings and reserve space for pipework and drainage under the verges and service strips.
- Where existing footways are excavated, they should be reinstated with matching materials to ensure coherent surfacing.
- Avoid any damage to the root system of retained tree species. Service runs should not be located within the tree root spreads or new tree planting corridors.
- Use sympathetic materials to the surrounding paved areas for manhole covers and make sure they fit with the surface material used. Integrate substations and other service kiosks into the design of new developments from the start.

Pipework & utilities

- Utilities are necessary parts in the operation of public and domestic environments. Special attention is required for selection and location utilities such as pipework and utility boxes. Poor planning of utilities could easily hinder the overall quality of the street scape in new developments.

Actions:

- The location and design of services on a building must be considered carefully and every effort should be made to locate these items as unobtrusively as possible.
- Pipework should be grouped together and run internally wherever practical. Chimneys can be used to disguise gas flues where they do not serve a working fireplace. By default, rainwater goods should be dark coloured unless they are matching a prevalent colour in the area.
- Meter boxes should be designed into a scheme from the outset to avoid cluttering the elevations. They should be on end rather than front elevations where possible. External meter boxes can be avoided through the use of smart meters.

Identity

ID.02 Legibility

Gaps

Actions:

- Narrow gaps between buildings should be avoided, generous gaps between buildings contribute to the general feel of openness of the area.
- Refer to the nominal dimensions on the next design code to guarantee sufficient separation between buildings.

Views

Actions:

- Consider the sequence of views and the appreciation of the view as one moves through the street scene. Consider where are the most likely viewpoints for key views and plan the arrangement of buildings, tree planting and open spaces accordingly.
- Buildings should be designed and arranged to reinforce views of existing landmarks and the open countryside through appropriate scale, mass and separation.
- Planting, particularly of trees with the potential of growing large, should be carefully planned so they don't obstruct from views of key assets to the village.

Topography

Actions:

- Consider the effect on topography on the possibility on perceiving distant views. Hill top positions can have attractive views towards the distant surroundings.
- Consider the impact of buildings on higher topographic levels and take measures to counteract the perception of overwhelming bulk of buildings on top of hills from lower viewpoints. Consider breaking the mass and roof line of such buildings and consider limiting the number of storeys.

This code is applicable to the following area types:
(Those areas where it is applicable are highlighted in colour)

A

B

C

D

E

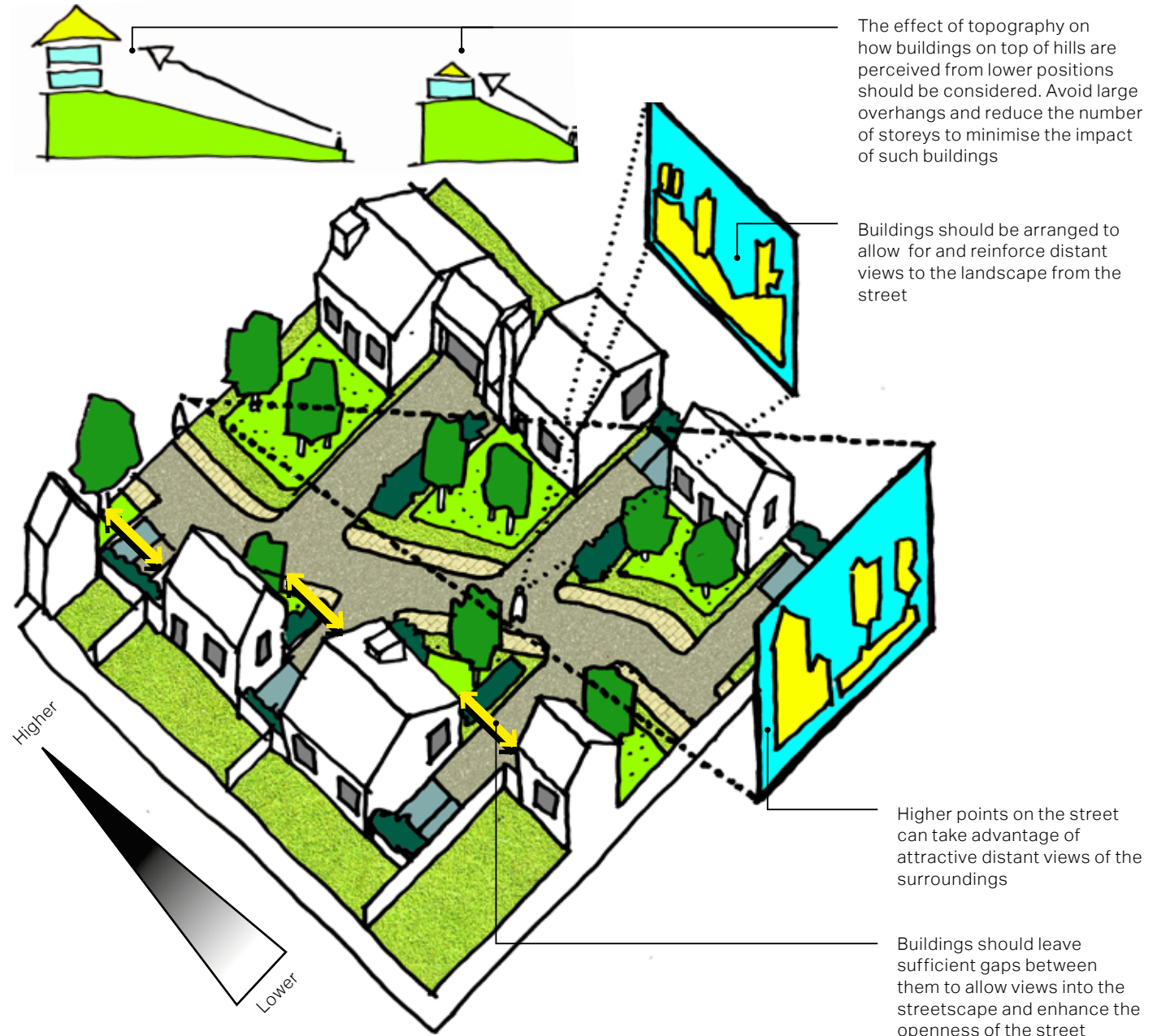

This code is applicable to the following area types:
 (Those areas where it is applicable are highlighted in colour)

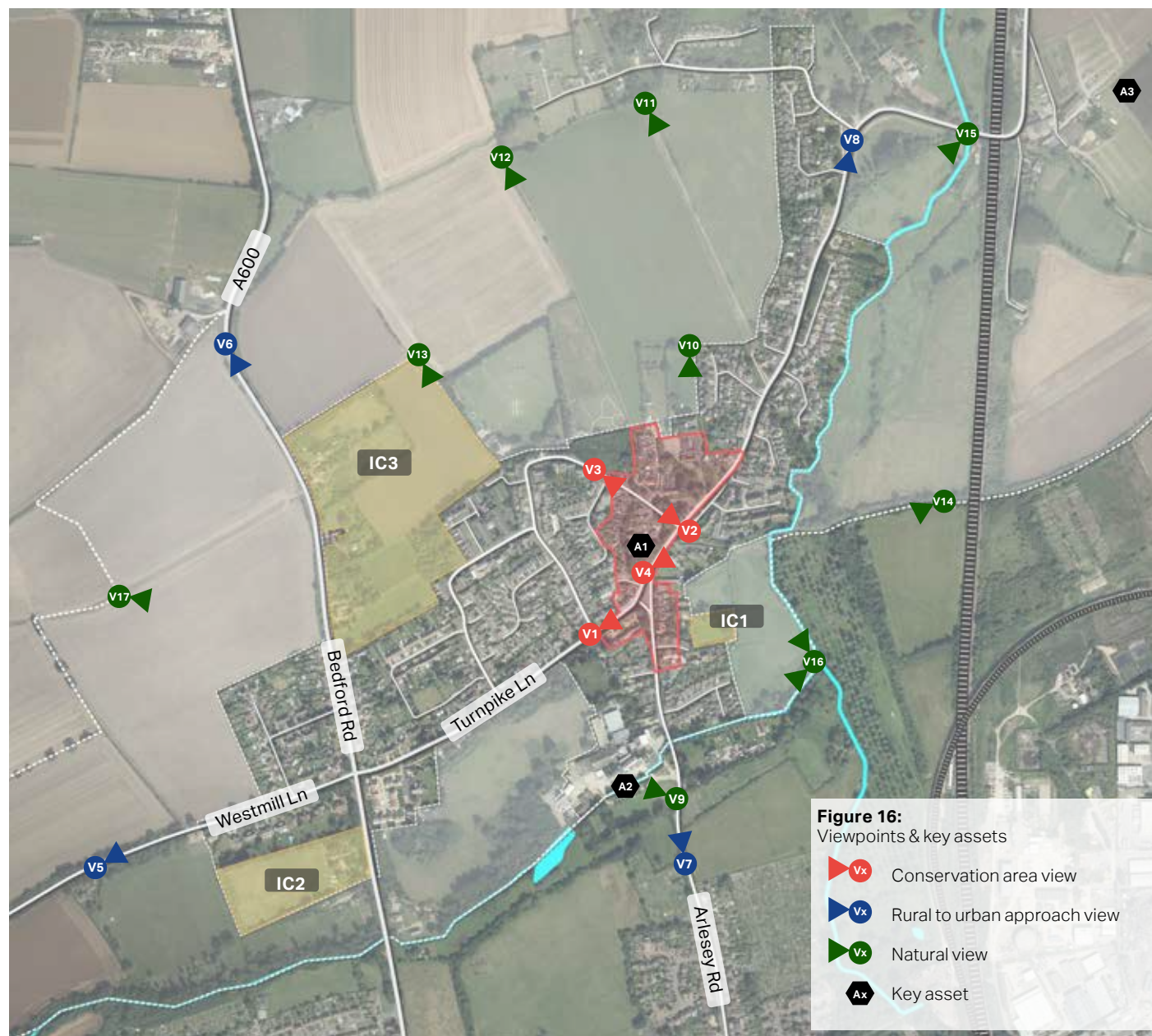

Figure 16:
Viewpoints & key assets

- ▶ Vx Conservation area view
- ▶ Vx Rural to urban approach view
- ▶ Vx Natural view
- Ax Key asset

Viewpoints and key assets

- The Conservation Area Character Statement issued in November 2019 by the District Council identifies the following key views within Ickleford Conservation Area:
 - 1) View north up Turnpike Lane from southern boundary of Conservation Area.
 - 2) View of village green from junction of Arlesey Road and Chambers Lane, looking west.
 - 3) View from Chambers Lane, looking south-east from exit of Conservation Area.
 - 4) View looking north along Arlesey Road from the junction of Arlesey Road and Turnpike Lane.
- A number of additional views, views 6 to 8, have been considered of value, they relate to the perception of the village when approaching it from the surrounding countryside. Some additional views, views 9 to 17, have been considered of value in relation to the perception of nature, water and village when observed from paths in the surrounding landscape.
- A number of key assets have also been identified as particularly valuable and prominent enough to have to be considered when assessing the impact new developments might have on them.
 - Asset 1: St Katharine’s Church
 - Asset 2: River Oughton at the Mill
 - Asset 3: Lavender Fields at Cadwell Farm

Actions

- New developments should consider their interaction with these key views and assets and maximise their enhancement while minimising the impact they might receive.

Identity

ID.03 Heritage assets

Step 1. Identify heritage assets and the effect on their setting

To assess the impact of development on heritage assets, the initial stage is to identify the assets and their setting that are likely to be affected by the proposal.

The setting of a heritage asset is 'the surroundings in which a heritage asset is experienced'. Where that experience is capable of being affected by a proposed development, then the proposed development can be said to affect the setting of that asset.



The Setting of Heritage Assets. Historic Environment: Good Practice Advice in Planning.

Historic England

2017

The codes in this section have been elaborated following the guidance on the The Setting of Heritage Assets. Historic Environment Good Practice Advice in Planning. Note 3 (Second Edition) published by Historic England and should be read in conjunction with it.

This code is applicable to the following area types:
(Those areas where it is applicable are highlighted in colour)



Local authority involvement

At pre-application stage, it is advisable to inquire the local authority so it can indicate whether it considers that a proposed development has the potential to affect the setting of a heritage asset. The local authority can specify an 'area of search' around the proposed development within which it is reasonable to consider setting effects



Immediate surroundings

For developments that are not likely to be prominent or intrusive, the assessment of effects on setting may often be limited to the immediate surroundings, while taking account of the possibility that setting may change as a result of the removal of impermanent landscape or townscape features



Assessment of large developments

The area of assessment for a large or prominent development can often extend for a distance of several kilometres. In these circumstances, while a proposed development may affect the setting of numerous heritage assets, it is advisable that local planning authorities work with applicants in order to minimise the need for detailed analysis



Large number of heritage assets

Where assessments of large numbers of heritage assets are required, Historic England recommends that local planning authorities give consideration to the practicalities of gathering and representing community interests and opinions on changes affecting settings



Viewing points

Where the development proposal affects views that affect the significance of an asset to be appreciated, it is often necessary to identify viewing points for assessment. An explanation why a particular viewing point has been selected will be needed

This code is applicable to the following area types:
(Those areas where it is applicable are highlighted in colour)

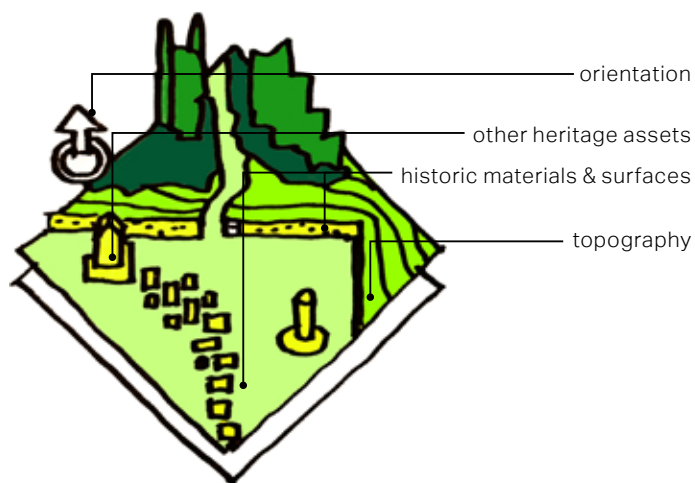

Physical surroundings of the asset

- Topography
- Other heritage assets (including buildings, structures, landscapes, areas or archaeological remains)
- Definition, scale and 'grain' of surrounding streetscape, landscape and spaces
- Formal design, hierarchy, layout
- Orientation and aspect
- Historic materials and surfaces
- Green space, trees and vegetation
- Openness, enclosure and boundaries
- Functional relationships and communications
- History and degree of change over time

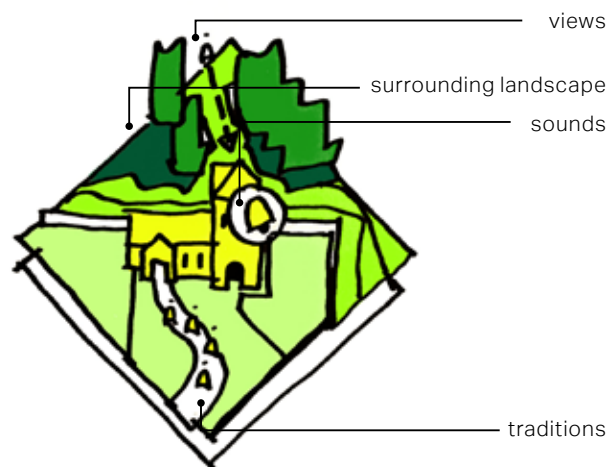

Experience of the asset

- Surrounding landscape or townscape character
- Views from, towards, through, across and including the asset
- Intentional intervisibility with other historic and natural features
- Visual dominance, prominence or role as focal point
- Noise, vibration and other nuisances
- Tranquillity, remoteness, 'wildness'
- Busyness, bustle, movement and activity
- Scents and smells
- Diurnal changes
- Sense of enclosure, seclusion, intimacy or privacy
- Land use
- Accessibility, permeability and patterns of movement
- Degree of interpretation or promotion to the public
- Rarity of comparable survivals of setting
- Cultural associations
- Celebrated artistic representations / traditions

Identity

Step 2. Assess the role of settings in the significance of heritage assets

The second stage of the analysis of the impact of development on heritage assets, is to assess whether the setting of an affected heritage asset makes a contribution to its significance and the extent and nature of that contribution.

This assessment should first address the key attributes of the heritage asset itself and then consider the following aspects:

Actions:

- Consider the physical surroundings of the asset, including its relationship with other heritage assets.
- Consider the asset's intangible associations with its surroundings, and patterns of use.
- Consider the contribution made by noises, smells, etc to the significance of the asset.
- Consider the way views allow the significance of the asset to be appreciated.

Identity

Step 3. Assess the effects of the development on the significance of the heritage asset and its appreciation

In general, the assessment of the effects of the development should address the attributes of the proposal in relation to its:

- Location and siting
- Form and appearance
- Wider effects
- Permanence

This code is applicable to the following area types:
(Those areas where it is applicable are highlighted in colour)

A

B

C

D

E



Location and siting of development

- Proximity to asset
- Position in relation to relevant topography and watercourses
- Position in relation to key views to, from and across
- Orientation
- Degree to which location will physically or visually isolate the asset



Form and appearance of development

- Prominence, dominance, or conspicuousness
- Competition with or distraction from the asset
- Dimensions, scale and massing
- Proportions
- Visual permeability (extent to which it can be seen through)
- Materials (texture, colour, reflectiveness, etc)
- Architectural and landscape style and/or design
- Introduction of movement or activity
- Diurnal or seasonal change



Wider effects of development

- Change to built surroundings and spaces
- Change to skyline, silhouette
- Noise, odour, vibration, dust, etc
- Lighting effects and 'light spill'
- Change to general character (i.e: urbanising or industrialising)
- Changes to public access, use or amenity
- Changes to land use, land cover, tree cover
- Changes to communications/accessibility/permeability, including traffic, road junctions and car-parking, etc
- Changes to ownership arrangements (fragmentation/permitted development/etc)
- Economic viability



Permanence of development

- Anticipated lifetime/temporariness
- Recurrence
- Reversibility

This code is applicable to the following area types:
(Those areas where it is applicable are highlighted in colour)



Initial condition

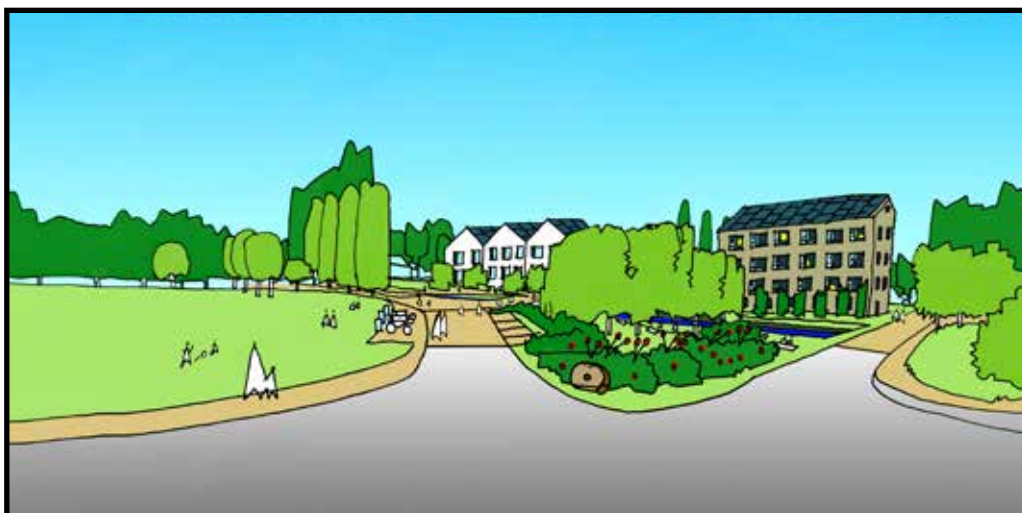

Maximise enhancement and reduce harm

Maximise enhancement

- Revealing heritage buildings obstructed by existing constructions of lower value can be a way of maximising enhancement.
- Conversion of existing structures is also a good way of enhancing the character of a place, as creative conversions can build on the history of a site, guaranteeing the functionality and the future of potent structures that live in the memory of residents.
- New landscaping and planting, minimising the impact of cars, improving pedestrian and cycle connectivity, and enhancing the leisure and amenity potential of green and blue infrastructure can have a substantial improvement on the living conditions of residents, while ameliorating the perception of the new development for both residents and visitors.

Reduce harm

- Conversion of buildings can typically save between 50 and 75 percent of the embodied carbon emissions compared to constructing a new building. This can be a good way of minimising harm.
- It can be argued that the perception of potentially aggressive development can be substantially improved with high quality landscaping.

Identity

Step 4. Maximise enhancement or minimise harm on the heritage asset

Maximise enhancement

Maximum benefits of development can be secured if any effects on the significance of a heritage asset likely to affect its setting are considered from the project's outset.

Actions:

- Removing or re-modelling an intrusive building or feature
- Replacement of a detrimental feature by a new and more harmonious one
- Restoring or revealing a lost historic feature or view
- Introducing a wholly new feature that adds to the public appreciation of the asset
- Introducing new views (including glimpses or better framed views) that add to the public experience of the asset
- Improving public access and interpretation of the asset and setting

Reduce harm

- Options for reducing the harm arising from development may include the repositioning of a development or its elements, changes to its design, the creation of effective long-term visual or acoustic screening, or management measures secured by planning conditions or legal agreements. Here the design quality may be an important consideration in determining the balance of harm and benefit.
- Where attributes of a development affecting setting may cause some harm to significance and cannot be adjusted, screening may have a part to play in reducing harm. It ought never to be regarded as a substitute for well-designed developments within the setting of heritage assets.

Identity

ID.04 Plots & blocks

Plots for houses

Minimum plot dimensions & conditions

In order to achieve the general separation and openness in the area, new plots should follow these general conditions. They determine the extent of the property boundary.

- Building height: maximum building height is 2 levels + pitch roof.
- Dwelling: Refer to code HO.01 for more detail on the minimum dimensions (width and depth) of the dwelling. A good reference for a house is to assume a footprint of 6 by 10m, in all cases:
 - Parking spaces should not develop beyond the main building line, unless they are provided as part of the front garden.
 - The main frontage of the dwelling should be facing the front garden.
 - Access to back garden corridor: minimum width of the corridor is 1m. Access to back gardens should be provided with a secure door.

Specific conditions for plots with parking to the front

- Front garden: the minimum depth of front gardens is 6m.
- Overall plot width: the preferable plot width is 12m, narrower plots should be used only on constrained sites.
- Overall plot depth: the minimum plot depth is 24m.

Specific conditions for plots with parking to the side

- Front garden: minimum depth of front gardens is 4m.
- Overall plot width: the minimum plot width is 12m, narrower plots should be used only on constrained sites.
- Overall plot depth: the minimum plot depth is 24m.

This code is applicable to the following area types:
(Those areas where it is applicable are highlighted in colour)

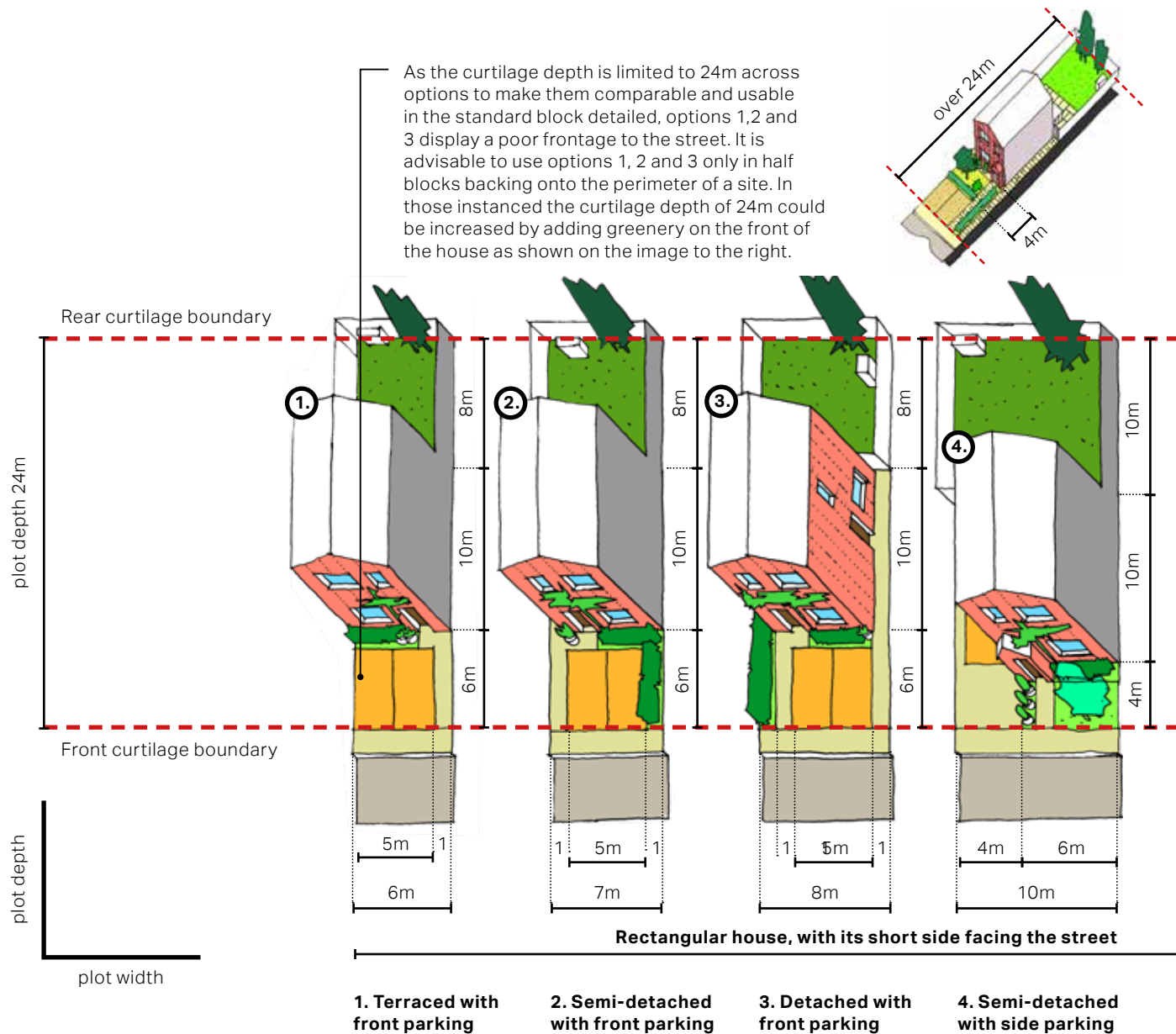

Parking spaces on the side of the dwelling should be overlooked. It is advisable to open windows on the facade looking at the spaces. The arrangement of typologies should be such that overlooking between dwellings is avoided. A good idea is to concentrate most windows on the east facade (in these cases) and almost none on the west, so the dwelling is overlooking just its own parking but the neighbouring facade is mostly blank.

Option 7, and also 4 and 5, are well suited to include garages. The minimum dimensions for an individual garage is 7x3m.

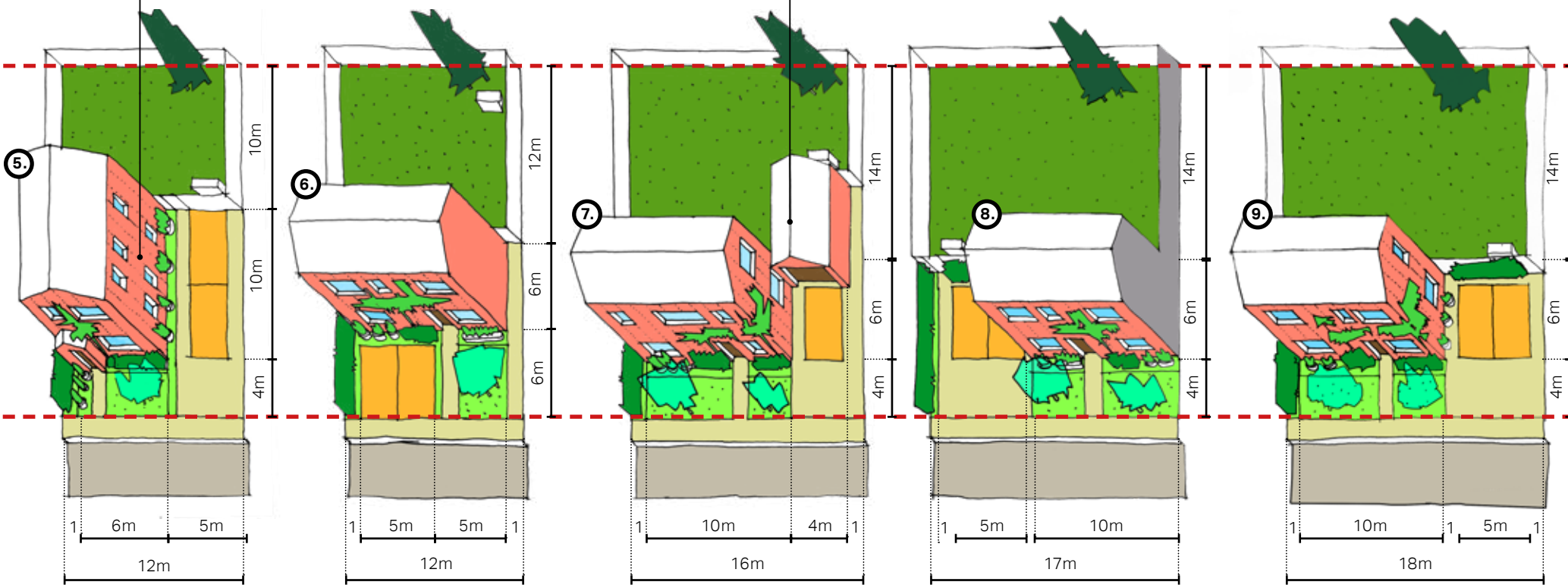

Rectangular house, with its long side facing the street

5. Detached with side parking

6. Detached with front parking

7. Detached with side parking (possible garage)

8. Semi-detached with side parking

9. Detached with side parking

Public space

PS.01 Access street

Access street

This street provides the main access spine of an area or a new development. It connects the development to the rest of the settlement.

Actions:

- Provide generous front gardens and street planting that contribute to the general feeling of openness.
- Locate parking to the side of properties and consider using garages to mitigate the impact of cars on the streetscape.
- Main street serves as the access to the new development and that can be acknowledged by providing planting in the junction with the existing road. Buildings in the access and ending can have special features to provide interest to the main spine.
- Local open spaces can ease way-finding as planting in corners, intersections with other streets and end of views, but also as separate open spaces in their own right. Provide those local green spaces, that are made accessible by being on the main structuring spine of the development.

This code is applicable to the following area types:
(Those areas where it is applicable are highlighted in colour)

A

B

C

D

E

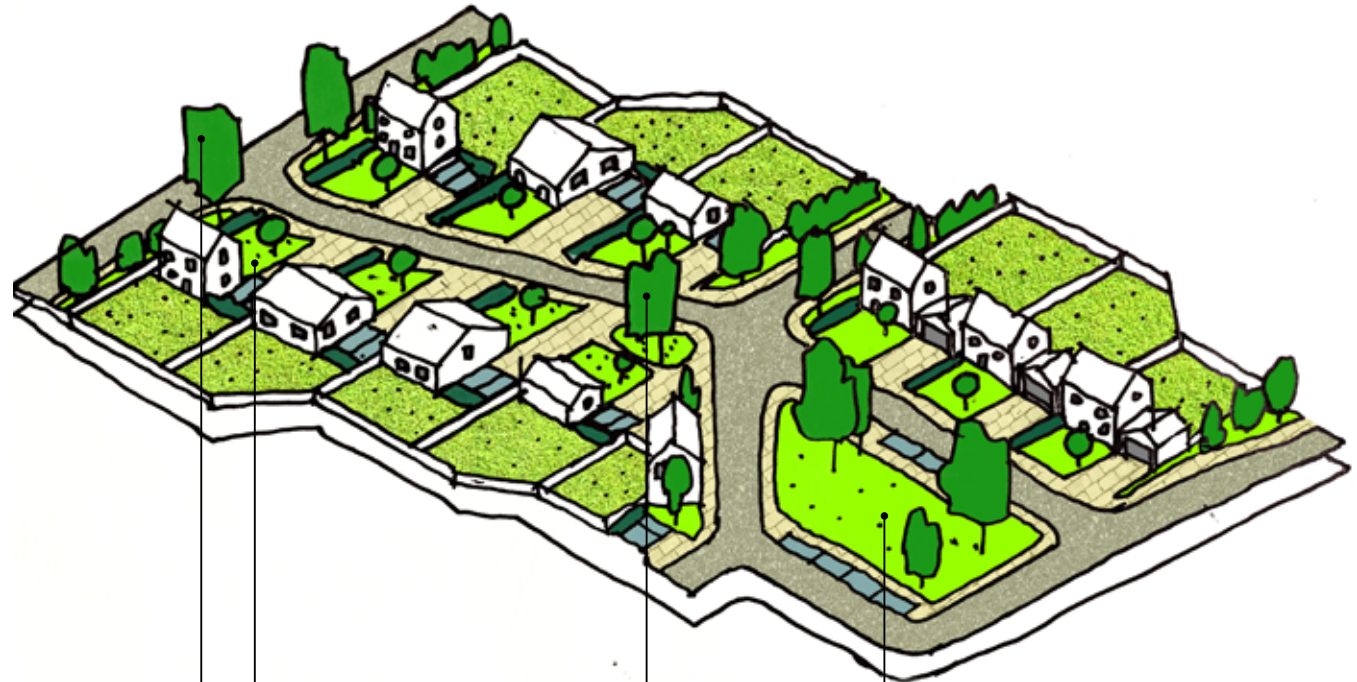

Provide generous front gardens that contribute to the openness of the street

Planting at key junctions and end of views can ease way-finding

Provide local green spaces, accessible by virtue of being located in the main street of the development, that include parking provision

Acknowledge the access to the new development with high quality planting in the junction with the existing road

This code is applicable to the following area types:
 (Those areas where it is applicable are highlighted in colour)

A B **C** D E

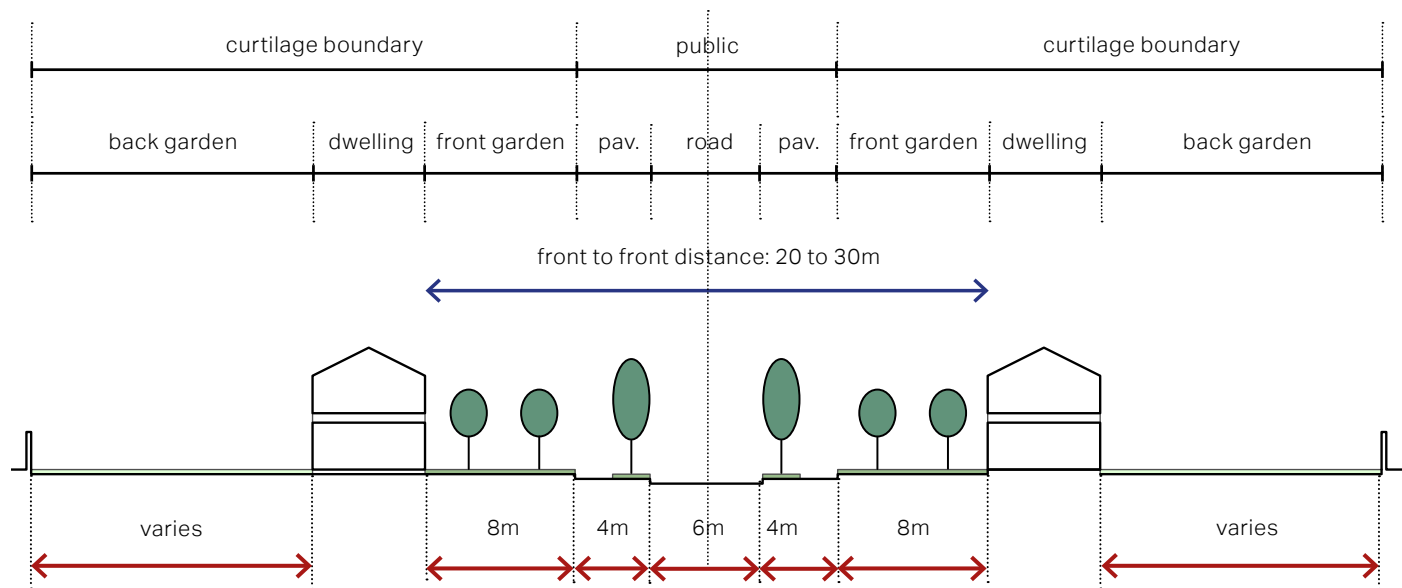

Walnut Way. Example of a local access street

Access street key dimensions

The nominal dimensions on the diagrams to the left are a guidance on the key elements and proportions to be provided on the main access street.

- Building height: maximum building height is 2 levels + pitch roof.
- Footways: a generally acceptable width of footways is 2m. An additional 2m is provided for street planting if required.
- Front gardens: minimum depth of front gardens is 8m. Tree planting is encouraged.
- Back gardens: minimum depth of back gardens is 15m.
- Front-to-front distance: the resulting street corridor width is in the range of 30m, contributing to the openness of the streetscape.

Examples

Walnut Way, to the left, is a local example of an access street. It includes some tree planting and a small green provision on the footway, the green character of the scene could be improved with additional tree planting.

In this case, the street does not include parking provision, which sometimes results in cars parked on the street.

Public space

PS.02 Residential street

Residential street

Actions:

- Provide generous front gardens that contribute to the general feeling of openness.
- Locate parking to the side of the property to mitigate the impact of cars on the streetscape.
- Residential streets branch out from the main street, it is good practice to stagger branching streets organically to avoid excessive long views.
- It is also advisable to stagger opposing buildings along the street so they are not directly facing each other, and therefore reduce the monotony along the streetscape.

Cul-de-sac street

Actions:

- It is generally acceptable to increase the density and decrease the spacing of buildings in cul-de-sacs to favour activity and prevent them from becoming isolated, parking can be at the front of properties in this case. Garages separate from dwellings are not acceptable and neither are parking courtyards.
- Cul-de-sacs should have pedestrian paths that connect them to surrounding areas and increase their connectivity access and overlooking. Careful consideration should be given to the landscaping and lighting of these paths to increase their safety. Follow Secure by Design principles included in Secure by Design Homes 2019 (or latest edition).
- Cul-de-sacs are typically backing onto the open land in the area. This is generally not advisable. It is generally advisable to back onto gardens of other properties. A side dwelling typology is suggested here as an alternative when properties back onto the open countryside. It provides distant views to the open land.

This code is applicable to the following area types:
(Those areas where it is applicable are highlighted in colour)

A

B

C

D

E

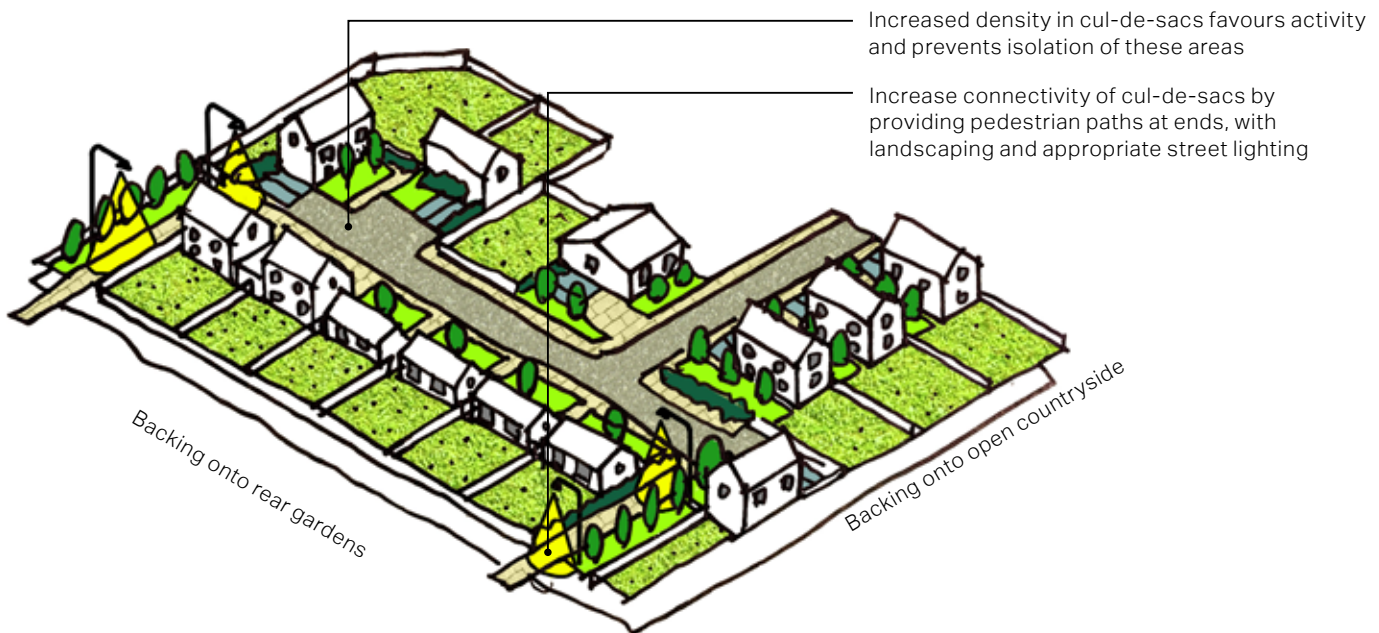
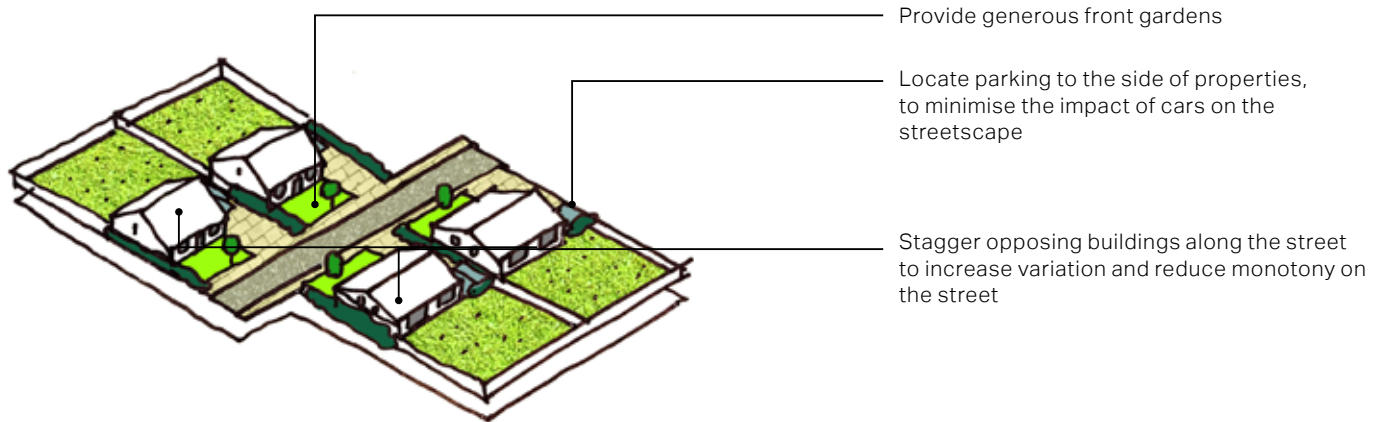

This code is applicable to the following area types:
 (Those areas where it is applicable are highlighted in colour)

A B **C** D E

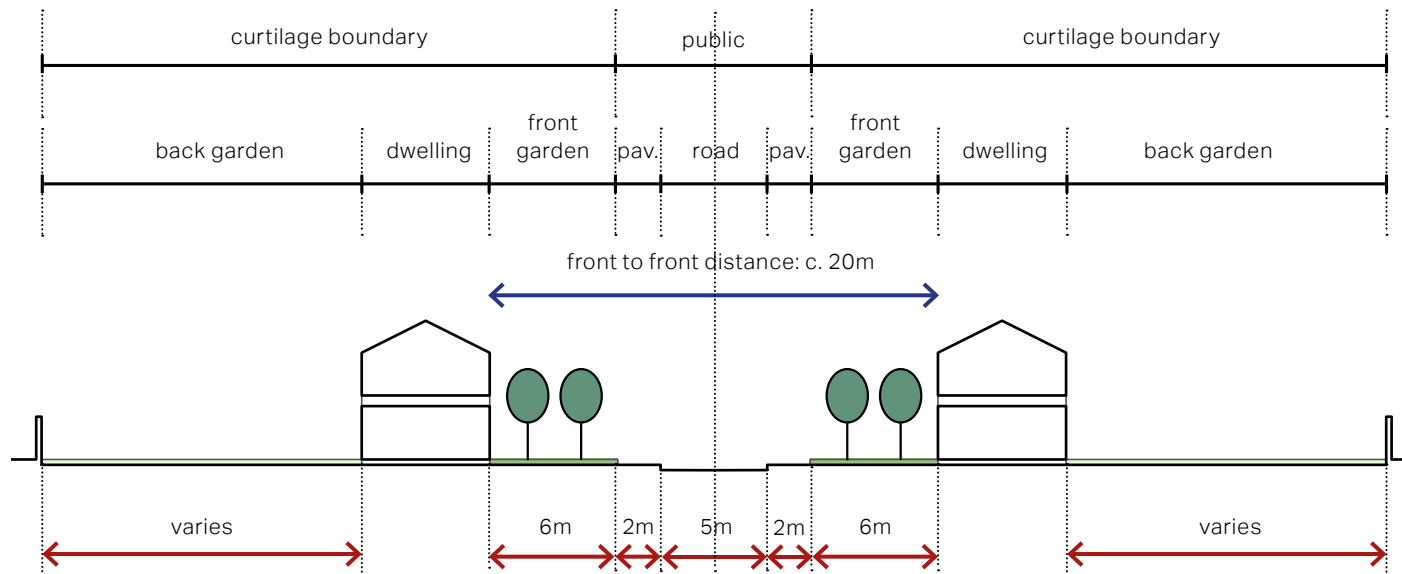

Residential street key dimensions

The nominal dimensions on the diagrams to the left are a guidance on the key elements and proportions to be provided on both residential and cul-de-sac streets.

- Building height: maximum building height is 2 levels + pitch roof.
- Footways: a generally acceptable width of footways is 2m. An additional 2m is provided for street planting if required.
- Front gardens: minimum depth of front gardens is 6m. Tree planting is encouraged.
- Back gardens: minimum depth of back gardens is 12m.
- Front-to-front distance: the resulting street corridor width is in the range of 20m, contributing to the general openness of the streetscape.

Examples

St Katharine's Close, to the left, is a local example of a cul-de-sac that is well overlooked and includes a green ending with a tree and a pedestrian connection to surrounding areas.

However, the safety of the pedestrian routes off the cul-de-sac could be improved by increasing overlooking and improving the landscaping and lighting of the path.



St Katharine's Close. Example of a local cul-de-sac

Public space

PS.03 Edge lane

Edge street / lane

Actions:

- Edge lanes are a suitable way of fronting the surrounding countryside making it accessible to most users.
- These streets can have gentle meandering, providing interest and evolving views while helping with orientation.
- Carefully consider landscaping as a buffer between development and the open countryside. This buffer future proofs the development against potential development that might front to the edge lane in the future.
- Connect the edge lane to paths and other public rights of way.

This code is applicable to the following area types:
(Those areas where it is applicable are highlighted in colour)

A

B

C

D

E

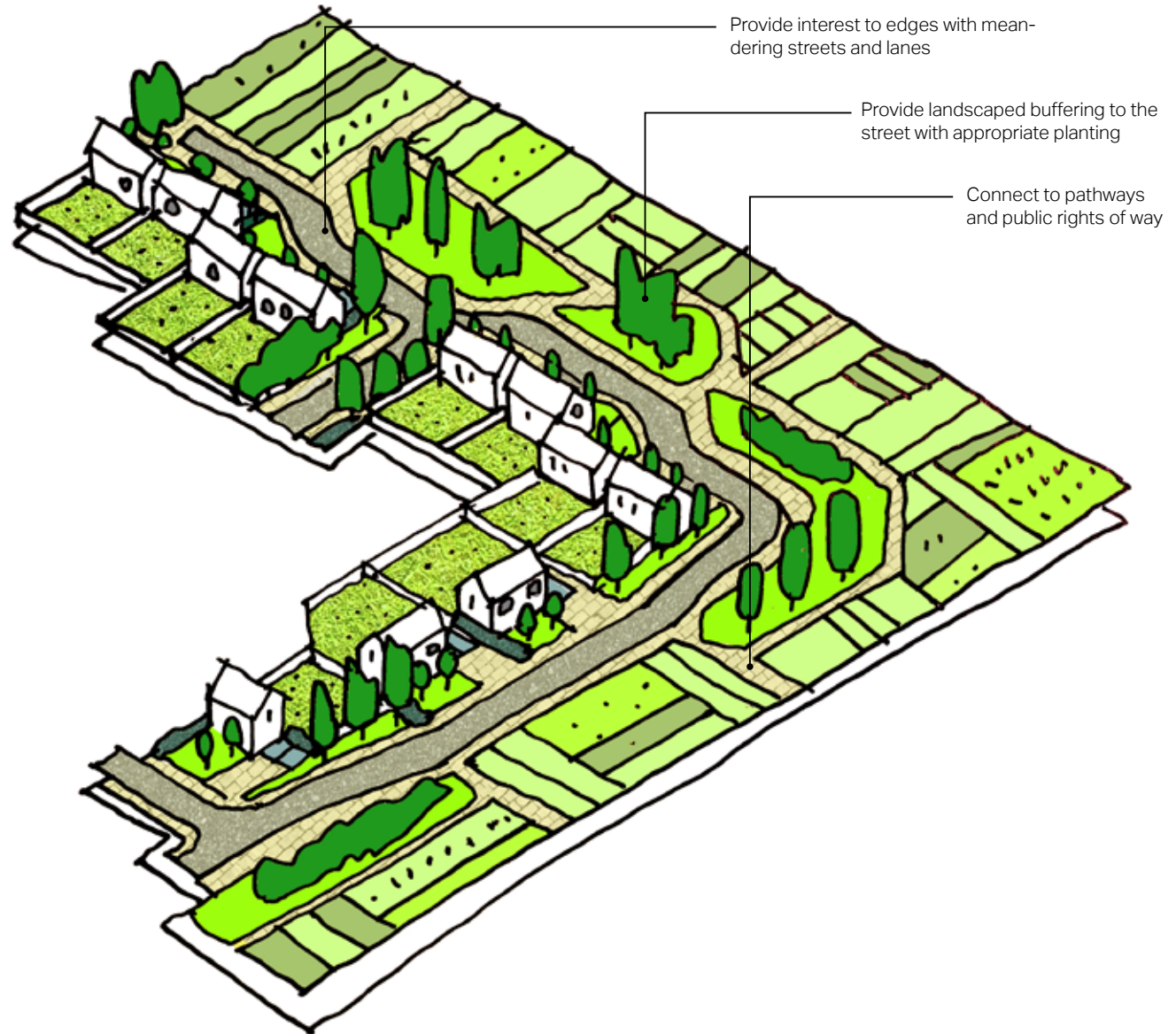

This code is applicable to the following area types:
 (Those areas where it is applicable are highlighted in colour)

A B **C** D E

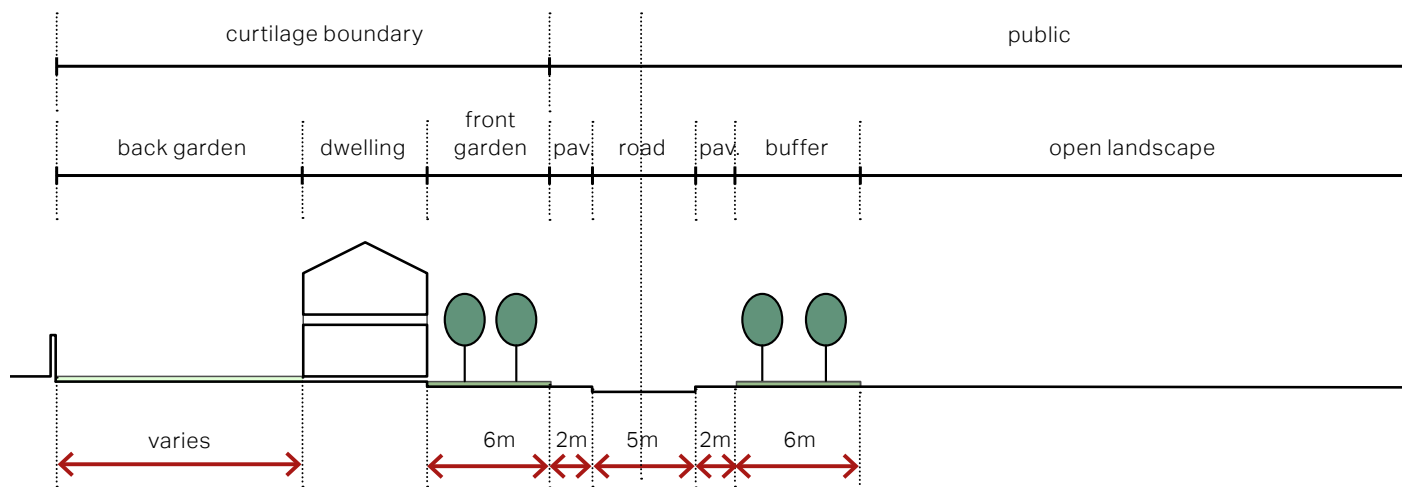

Edge lane key dimensions

The nominal dimensions on the diagrams to the left are a guidance on the key elements and proportions to be provided on the main access street.

- Building height: maximum building height is 2 levels + pitch roof.
- Footways: a generally acceptable width of footways is 2m.
- Front gardens: minimum width of front gardens is 6m. Tree planting is encouraged.
- Back gardens: minimum width of back gardens is 12m.
- Buffer landscaping: this buffer guarantees separation from the open countryside, and from potential new developments that might come forward beyond the boundary of the current site. A minimum buffer distance of 6m is represented in this diagram.

Examples

Snailswell Lane, to the left, is a local example of an edge lane. Overlooking of the lane could be improved, as it is the back of properties that is facing the landscape, it is generally a good practice to orient the fronts of properties to the open landscape when possible. The connectivity to pathways and the landscape beyond could also be improved. A good reference of an edge lane in the settlement is Chambers Lane (below).



Snailswell Lane. Example of a local edge lane



Public space

PS.04 Secured by design

Safe and lively spaces

- Designing out crime and designing community safety is essential to the creation of successful, safe and attractive developments. The following guidelines are in line with the latest manual endorsed by the police 'Secured by Design Homes 2019'.

Actions:

- Access and movement: design places with well-defined routes, spaces and entrances that provide for convenient movement without compromising security.
- Structure: design places that are structured and easy to read, so that different uses do not cause conflict.
- Activity: design places where the level of human activity is appropriate to the location and creates a reduced risk of crime and a sense of safety at all times.
- Surveillance: design places where all publicly and privately-owned open spaces (such as front gardens and driveways) are overlooked. Provide adequate levels of street lighting. Ensure that lighting schemes do not cause unacceptable levels of light pollution particularly in intrinsically dark areas. These can be areas very close to the countryside or where dark skies are enjoyed. Consider lighting schemes that could be turned off when not needed ('part-night lighting') to reduce any potential adverse effects on sensitive wildlife.
- Ownership: design places that promote a sense of ownership, respect, territorial responsibility and community-compromising well defined dwelling boundaries;
- Physical protection: design places that include necessary, well-designed security features, such as boundary walls and party fences.
- Management and maintenance: design places that are designed with ease of management and maintenance in mind, to discourage crime in the present and the future.

This code is applicable to the following area types:
(Those areas where it is applicable are highlighted in colour)

A

B

C

D

E

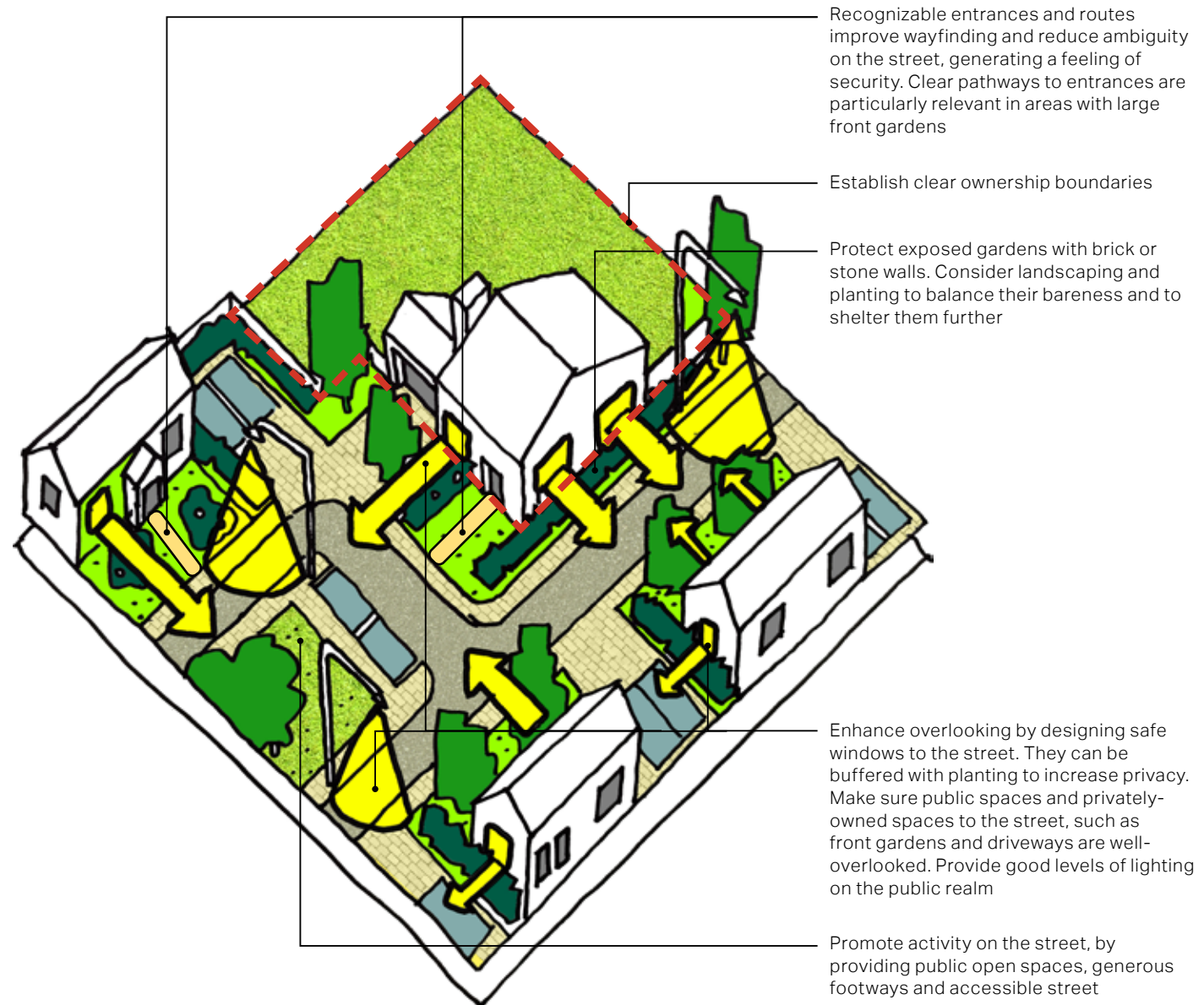

This code is applicable to the following area types:
(Those areas where it is applicable are highlighted in colour)

A

B

C

D

E

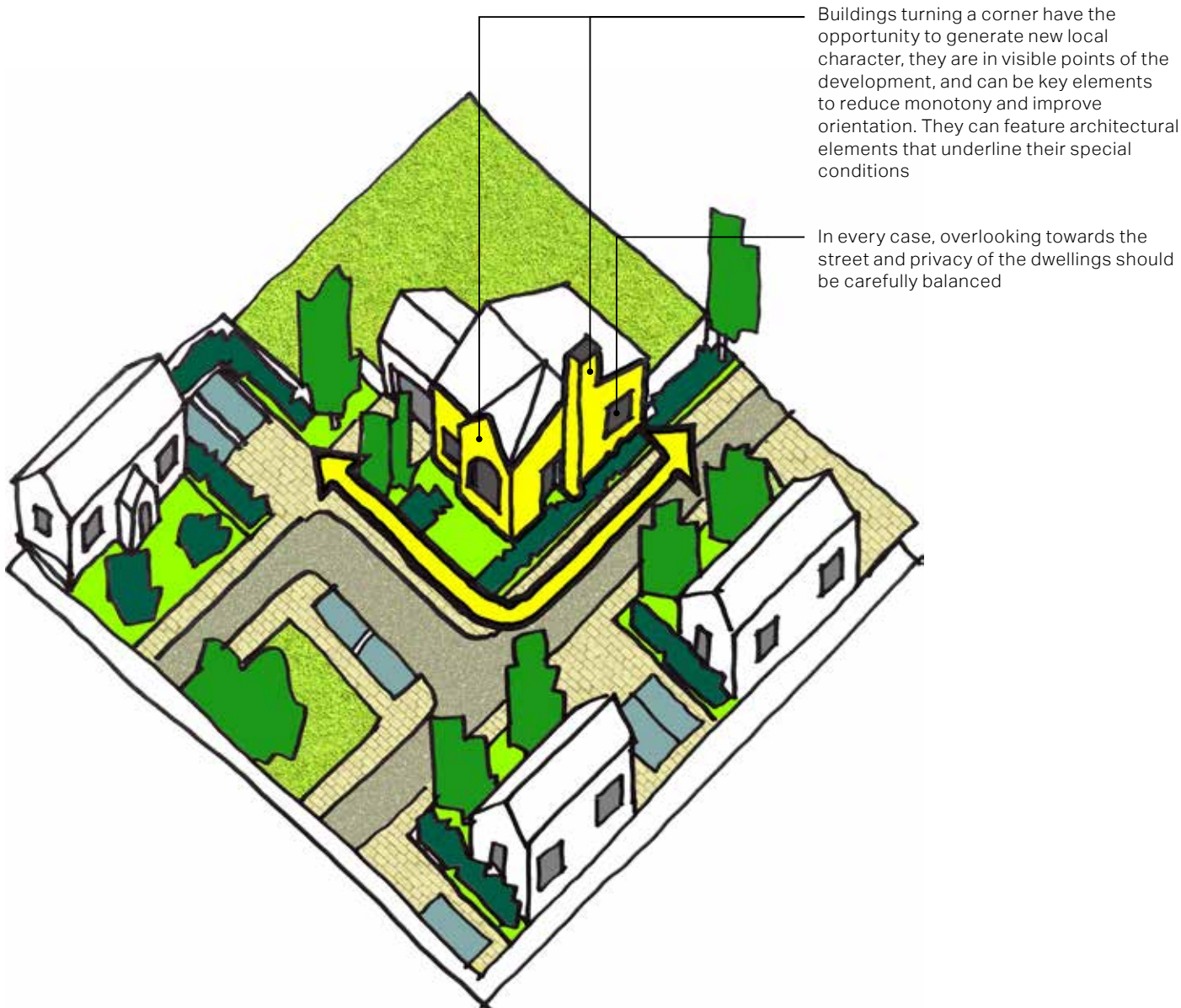

Buildings turning a corner have the opportunity to generate new local character, they are in visible points of the development, and can be key elements to reduce monotony and improve orientation. They can feature architectural elements that underline their special conditions

In every case, overlooking towards the street and privacy of the dwellings should be carefully balanced

Buildings turning a corner

Streets with active frontages provide visual attractiveness and enhance the streetscape, but also provide high levels of natural surveillance.

Actions:

- Animate both facades on a corner buildings with doors and/or windows. Exposed, blank gable end buildings with no windows fronting the public realm should be avoided.
- Consider decorative architectural feature elements for these building types, given their prominence and their ability to create local character.
- As well as relating carefully to existing heritage features, landmark buildings should also be innovative and interesting. They should promote good architecture and ensure that places are distinct, recognisable and memorable.
- In any case, privacy measures should be taken into account from the early design stage. Issues such as overlooking from streets, private and communal gardens should all be considered. Setback from the street, front garden landscaping and detailed architectural design should help in balancing privacy to front living spaces with the need for overlooking of the street.

Uses

US.01 Shops

Location

- Locate new shops where they can be more beneficial to residents, it is normally advised to use the ground floor of apartment buildings to that effect, as they tend to have higher population density and a positive impact on the activation of the streetscape. Corner shops are a better option than single facing ones.

Respect the neighbours

- Make sure that the shops are operational only during some periods of the day time. Make sure they do not disturb residents peace and resting times. Provide noise barriers and proper insulation at that effect.

Reflect the building & the street

- Consider the overall proportion, form, scale and materiality of the building's upper floors when designing new shop fronts and alterations.
- Integrate the shop front with the street, introducing variety but responding to the character of the area. Consider activating the streetscape with commercial uses outside of the shop, such as seating areas for cafes. Take into consideration their visual impact and make sure they do not obstruct the pedestrian route.

De-clutter

- Unnecessary visual clutter should be avoided. This includes reducing unnecessary advertisements, plastic foliage or other elements stuck onto the shopfront, and removing general detritus such as visible AC units, wires and intrusive roller shutter boxes. Avoid using external roller shutters and grilles. Favour the use of internal open grilles which cover only the glazed part of the shopfront.
- Conceal alarms from the shop front facade and integrate them discretely within the shop front design.

Materials & lighting

- Historically, shop fronts and signs were constructed using timber. Consider using wood as appropriate.
- Avoid using visually distinct sources of illumination that result in intrusive signage, such as internally-illuminated box signs

This code is applicable to the following area types:
(Those areas where it is applicable are highlighted in colour)



Make sure shops do not disturb residents peace and resting times

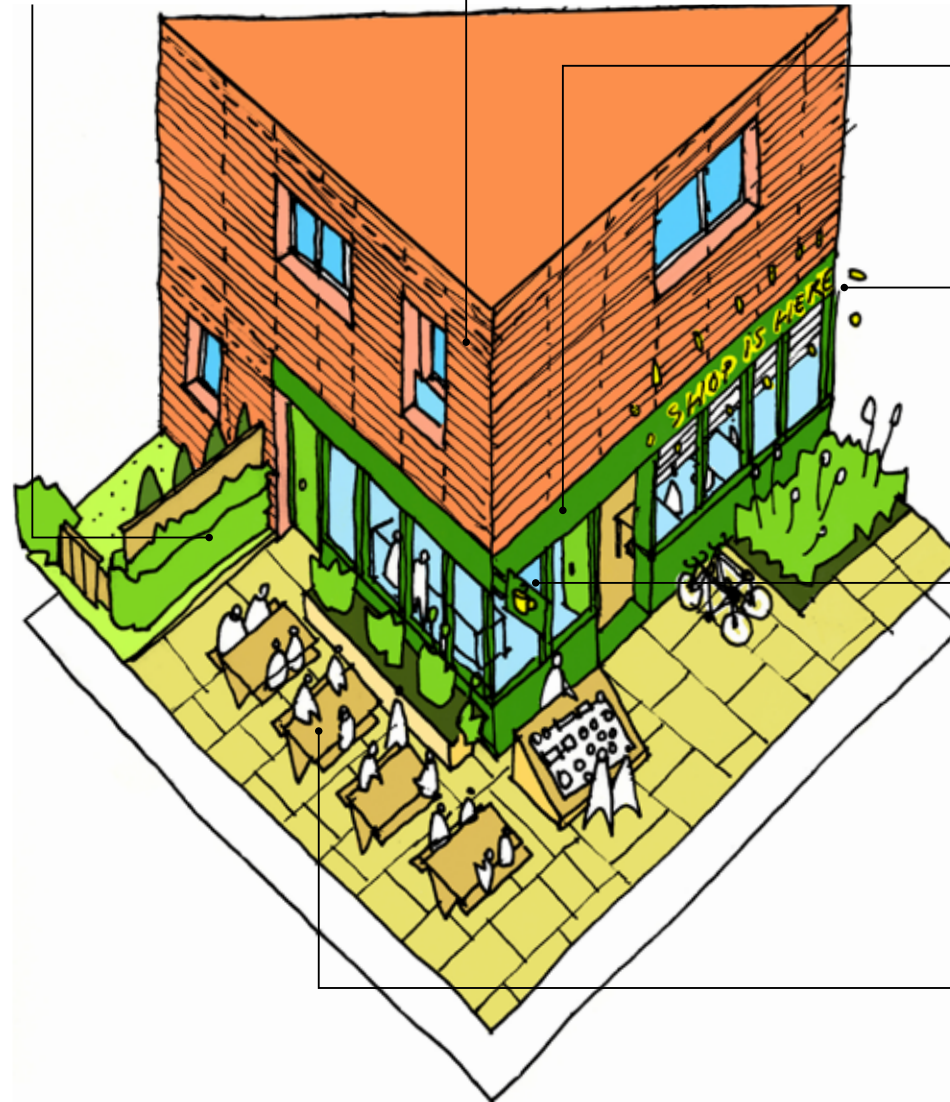

Corner shops are more impactful if located near residents and in denser areas, such as apartment buildings

Corner shops can result in more street activation compared to those on just one facade

Avoid using visually distinct sources of illumination that result in intrusive signage, such as internally-illuminated box signs

Unnecessary visual clutter should be avoided. Be careful with protruding signage

Consider activating the streetscape with commercial uses outside of the shop, such as seating areas for cafes. Take into consideration their visual impact and make sure they do not obstruct the pedestrian route.

This code is applicable to the following area types:
 (Those areas where it is applicable are highlighted in colour)

- A
- B
- C
- D
- E



Locate play areas within walking distance from its target users, connect them to green networks and pathways

Make surrounding buildings overlook play areas and public spaces

Make playgrounds accessible and consider the design guidance for the different types of playground

Include landscaping within and around play areas

Associate playgrounds with other leisure and communal activities, such as gyms and allotments

Uses

US.02 Community uses

Play areas

Open spaces and play areas play a vital role in creating a positive environment. These are places fostering community and gathering; thus creating lively places in the area.

Actions:

- New play areas should be located within walking distance from their intended users. If appropriate, these should be linked to form connected green networks and pathways. The networks are often more useful for visual amenity, recreational use and wildlife corridors than as isolated parks.
- Where direct links are not possible, it may be appropriate to link these together through green routes, shared surface and streets.
- Playgrounds can be associated with other leisure and communal activities. Consider providing outdoor gym equipment, allotments, and other amenities together with play areas.
- Make surrounding buildings overlook play areas and public spaces and where possible. The location of play spaces should take into account the context.
- Play spaces should be accessible to all children. Reference should be made to existing national guidance on inclusive play. When designing and planning play areas also consider seating areas for carers, shaded spaces and avoiding hidden spots.
- Consider the existing guidance on designing LAPs (Local Area for Play), LEAPs (Local Equipped Area for Play), and NEAPs (Neighbourhood Equipped Area for Play) and their spatial requirements in relation to the size and catchment area of the development.
- Play areas should also include elements relating to nature and landscape. The equipment and fittings considered should be of high quality, durability and conforming to the relevant standard as defined by the District Council.

Homes & buildings

HO.01 Space standards

Houses

The following examples summarize the minimum room dimensions and spatial requirements for new house typologies in the area. This section illustrates the versatility of a base dwelling of 10x6m and 10x10m footprint.

The minimum dimensions for each room are as follows:

Living room

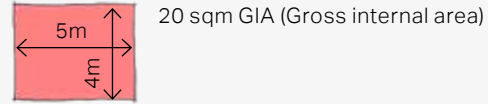

Kitchen

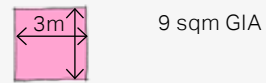

Single bedroom

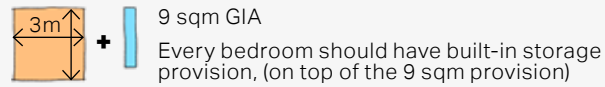

Double Bedroom

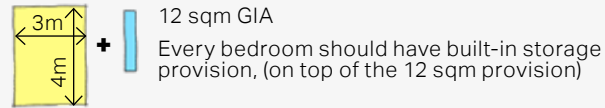

Single bathroom

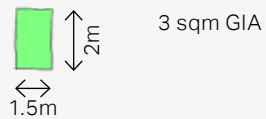

Double bathroom



This code is applicable to the following area types:
(Those areas where it is applicable are highlighted in colour)

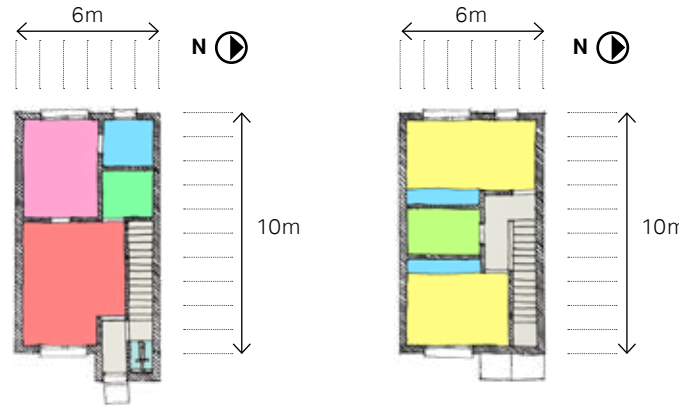

A. Rectangular 2 bedroom house, with its short side facing the street

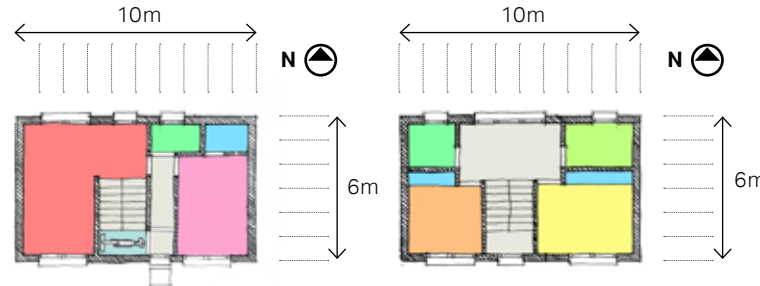

B1. Rectangular 2 bedroom house, with its long side facing the street and street access on the main solar incidence facade

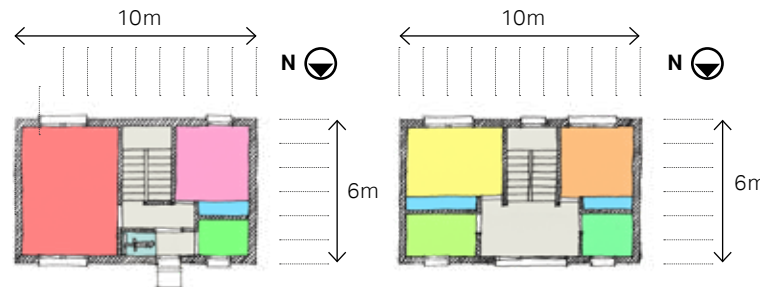

B2. Rectangular 2 bedroom house, with its long side facing the street and street access on the opposite facade to the main solar incidence facade

Axonometric view of dwelling type A

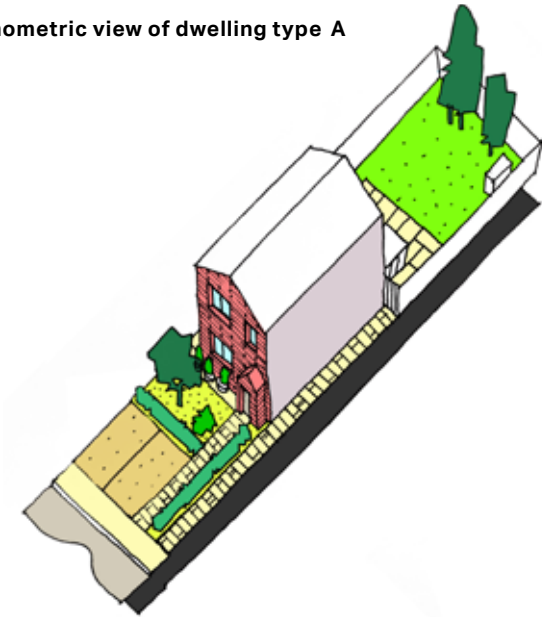

Axonometric view of dwelling type B2

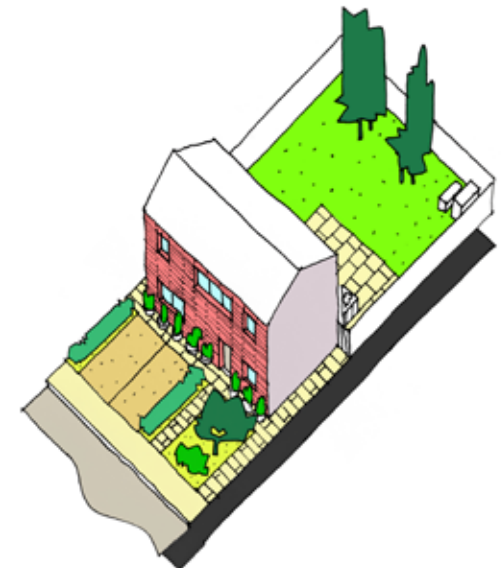



C1. L-shaped 3 bedroom house
 Either as a corner building or as an one-storey extension of the type B1



C2. L-shaped 3 bedroom house
 Either as a corner building or as an one-storey extension of the type B2



C3. L-shaped 4 bedroom house
 Either as a corner building or as a two-storey extension of the type B1



C4. L-shaped 4 bedroom house
 Either as a corner building or as a two-storey extension of the type B2

Axonomic view of dwelling type C4

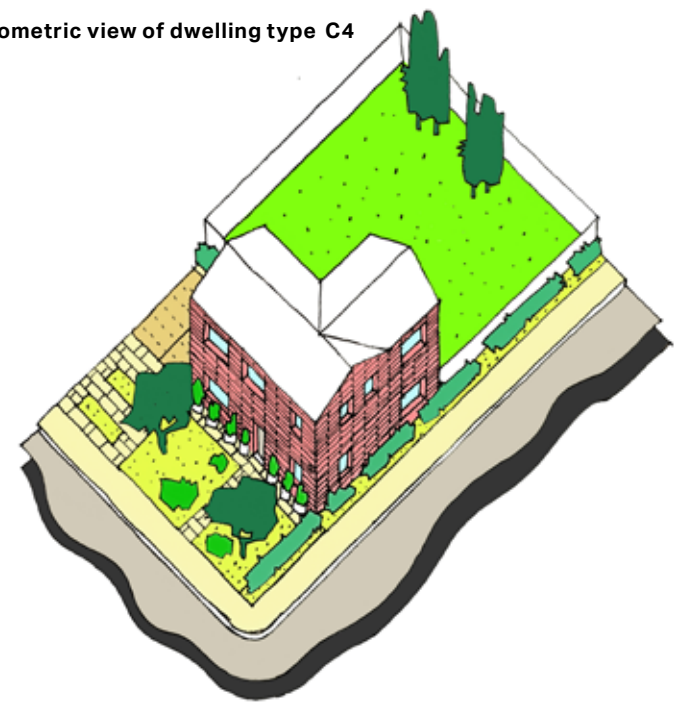

Homes & buildings

HO.02 Accessibility

Houses for a lifetime

Houses should be designed to meet the differing and changing needs of households and peoples' physical abilities over their entire lifetime. One way to achieve this is to incorporate Lifetime Homes Standards design criteria in the design of new homes and to assess whether they can be retrofitted in existing properties.

The diagram to the right illustrates the main principles of inclusivity, accessibility, adaptability and sustainability.

Actions:

- Any new housing development must meet the M4(2) standards for accessible and adaptable homes. Any new development of 10 or more homes must provide 10% to M4(3) standard for wheelchair accessible homes.
- Any new housing development must accommodate 50% of the dwellings which meet the requirements for accessible and adaptable dwellings under Part M4(2) of Building Regulations (or any relevant regulation that supersedes and replaces).

This code is applicable to the following area types:
(Those areas where it is applicable are highlighted in colour)

A

B

C

D

E

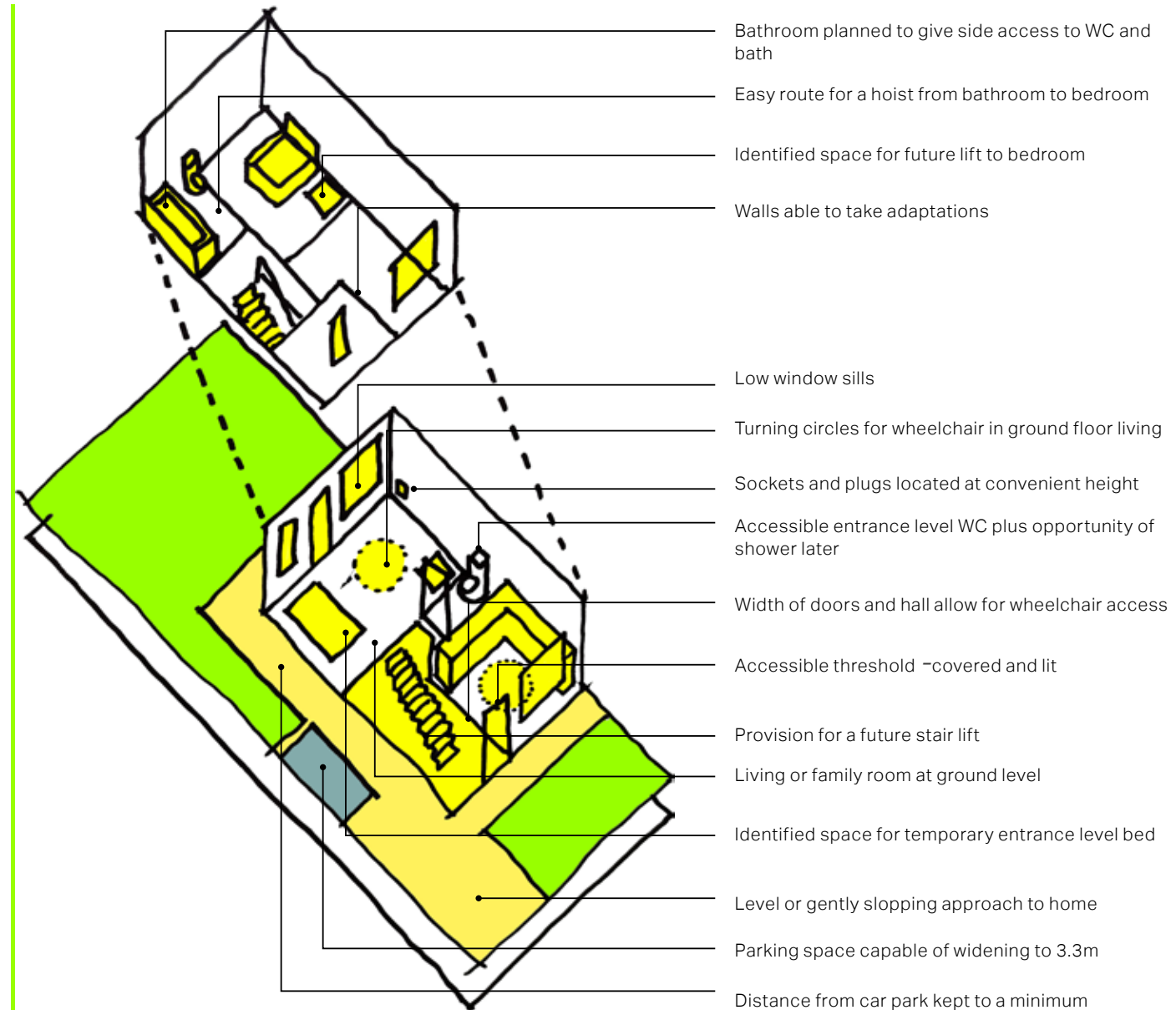

This code is applicable to the following area types:
(Those areas where it is applicable are highlighted in colour)



The Grade II listed brick and stone wall to Ickleford Primary School



Boundary limit marked with hedgerow in Arlesey Road



Bare wooden or metal fencing facing directly onto the street should be avoided, even if present in areas of Ickleford, this is generally not an ideal choice for new areas. A hedgerow on the external face of the fence would be preferable.



In this case, the fencing is accompanied with planting, substantially improving the frontage to the street

Homes & buildings

HO.03 Gardens & boundaries

Gardens

Front gardens can contribute positively to the character of the street scene. A well-maintained front garden adds to the overall look of the area.

Rear gardens can provide additional well-being benefits, as places to sit, eat and relax. They constitute opportunities to grow vegetables and fruits and can be appropriate places to install outdoor office spaces and working areas.

Planting

Actions:

- The British Standard 5837: 2012 'Trees in relation to construction- Recommendations' should be the reference document when considering new and existing trees on proposed development sites.
- Existing trees should be retained as much as possible.

Boundary treatments

Quality landscaping and well-thought boundary treatments are key to achieving attractive streets. Make good use of hedges, trees, flower beds, low walls and high quality paving materials between the private and public space.

Actions:

- If low level boundary demarcation of front gardens is required for security or given the conditions of the street, it will not normally be appropriate to allow fences higher than 1 metre to the street and 1.8 metres to the rear, to separate back gardens.
- The selected material to mark curtilage boundaries will need to be appropriate to the surroundings and in keeping with that of neighbouring properties, wooden boarding is generally not advisable and brick and planting is preferred, as is in keeping with the traditional boundary treatments in the area.
- Generally, wooden fencing can be used for concealed rear and side gardens backing onto each other, if these gardens are never facing the street or open spaces.

Homes & buildings

HO.04 Extensions

General considerations

Extensions to dwellings can have a significant impact on the character and appearance of the building, but also on the streetscene within which they sit. A well-designed extension can enhance the appearance of its street, whereas an unsympathetic extension can have a harmful impact, create problems for neighbouring residents and affect the overall character of the area.

Even if this section is not mandatory where work falls within the definition of permitted development, it can be considered as a design reference in Ickleford to achieve a cohesive and positive character in keeping with the village built form.

Actions:

- Alterations and extensions within the conservation area should reflect local character through the use of characteristic materials and detailing.
- All extensions should be appropriate to the mass, scale and design of the main building and should not exceed the height of the original or adjacent buildings. Two storey extensions should be constructed with the same angle of pitch as the existing roof.
- The form of extensions should respect the shape and style of the roof. Reference should be taken from the host building and the local vernacular to determine the most appropriate proportions for the extension.
- Innovative and creative material and design suggestions in extensions that complement the host building may be appropriate, but should always reflect local character in their form, scale and massing.
- Design codes BF.06, BF.07, BF.08 and BF.09 should also be followed in relation to modifications and extensions.

General forms

Actions:

- The original building should remain the dominant element of the property regardless of the amount of extensions. The newly built extension should not overwhelm the building from any given point.

This code is applicable to the following area types:
(Those areas where it is applicable are highlighted in colour)



- Avoid designs that wrap around the existing building and involve overly complicated roof forms.

Roof extensions

The pitch and form of the roof of buildings adds to its character and extensions should respond to this where appropriate.

Actions:

- Wherever possible, locate roof extensions to the rear of properties to minimise potential impact on the streetscape.
- Favour rooflights as a way of introducing natural light into a roofspace without resulting in negative visual impact.

Extensions to side

Actions:

- Side extensions should be set back from the front of the main building, mirror the roof pitch, replicate or have lower cornice height, and ridges should be below the existing ridge height. Take careful consideration to avoid overshadowing of the neighbouring plot.
- Set-back the extension by at least 50cm from the main facade or at least by 1m if the extension is a car garage.
- A minimum distance of 1m between the property and its boundary (giving a total distance of at least 2m between properties) should be maintained by new side extensions.

Extensions to front

Actions:

- In general, front extensions have a greater impact on the street, and so should be avoided.
- Front extensions should take the form of the existing building, mirror the roof pitch, replicate or have lower cornice height and their ridge should be below the existing ridge height.

Extensions to rear

Actions:

- Rear extensions should take the form of the existing building, mirror the roof pitch, replicate or have lower cornice height, and ridges should be below the existing ridge height. Take careful

consideration to avoid overshadowing of the neighbouring plot.

Loss of private amenity

Actions:

- Extensions should not result in a significant loss to the private amenity area (front, side and rear gardens) of the dwelling.

Architectural language & materials

Actions:

- Extensions should consider the materials, architectural features, window sizes and proportions of the existing building and recreate this style to design an extension that matches and complements the existing building. The original building should remain the dominant element of the property regardless of the amount of extensions. The newly built extension should not overwhelm the building from any given point.

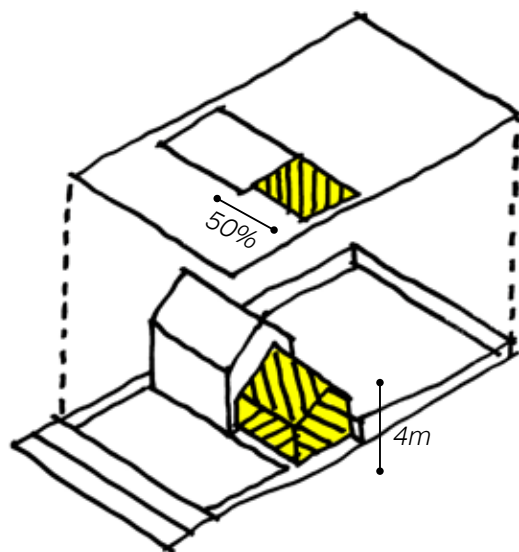

Extensions to side

- Only half the area of land around the original house can be covered by extensions or other buildings.
- Extensions cannot be higher than the highest part of the existing roof; or higher at the eaves than the existing eaves.
- Where the extension comes within two metres of the boundary the height at the eaves cannot exceed three metres.
- The extension cannot exceed four metres in height.
- The extension can only be a single storey.
- The extension can only be up-to half the width of the original house.

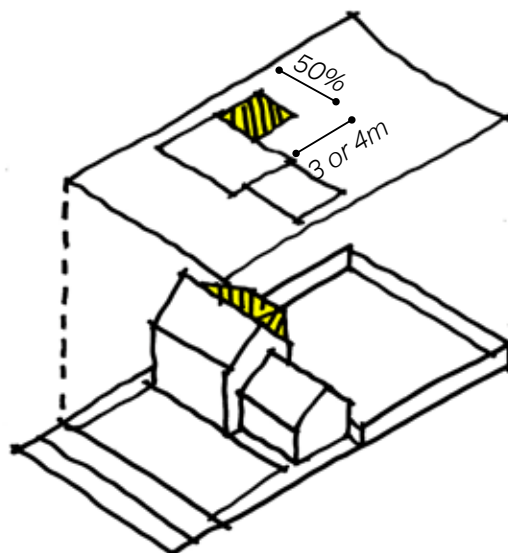

Extensions to back

- Only half the area of land around the original house can be covered by extensions or other buildings.
- Extensions cannot be higher than the highest part of the existing roof; or higher at the eaves than the existing eaves.
- Where the extension comes within two metres of the boundary the height at the eaves cannot exceed three metres.
- The extension cannot exceed four metres in height.
- The extension can only be a single storey.
- Single-storey rear extensions cannot extend beyond the rear wall of the original house by more than four metres if a detached house; or more than three metres for any other house.

Permitted development

Permitted development rights allow you to extend a house without needing to apply for planning permission, if specific limitations and conditions are met. If you want to exceed these, then it is likely that an application for householder planning permission will be required.

All extensions

- Only half the area of land around the original house can be covered by extensions or other buildings.
- Extensions cannot be higher than the highest part of the existing roof; or higher at the eaves than the existing eaves.
- Where the extension comes within two metres of the boundary the height at the eaves cannot exceed three metres.
- Extension cannot be built forward of the 'principal elevation' or, where it fronts a highway, the 'side elevation'.

Side extensions

Where it would extend beyond the 'side elevation' of the original house, the extension:

- Cannot exceed four metres in height.
- Can only be a single storey.
- Can only be up-to half the width of the original house*.

Single storey extensions

- Single-storey rear extensions cannot extend beyond the rear wall of the original house by more than four metres if a detached house; or more than three metres for any other house.
- Single-storey rear extensions cannot exceed four metres in height.

Extensions of more than one storey

- Extensions of more than one storey must not extend beyond the rear wall of the original house* by more than three metres or be within seven metres of any boundary* opposite the rear wall of the house.
- Roof pitch must match existing house as far as practicable (note that this also applies to any upper storey built on an existing extension).
- Any upper-floor window located in a 'side elevation' must be obscure-glazed and non-opening (unless the openable part is more than 1.7 metres above the floor).
- All side extensions of more than one storey will require householder planning permission.

For further information on permitted development Refer to https://www.planningportal.co.uk/info/200130/common_projects/17/extensions

Energy & sustainability

SU.01 Low Carbon

A number of factors can have an effect in reducing the impact that the built environment can have on the planet resources. In this section we will focus on orientation, materials and technologies.

Orientation

Buildings should be designed to maximise solar gain, daylight and sun penetration, while avoiding overheating. Subject to topography and the clustering of existing buildings, they should be orientated to incorporate passive solar design principles. These principles include:

- All new residential units should be dual aspect, unless provision of dual aspect is demonstrated to be impossible or unfavourable. North facing single aspect units should be avoided or mitigated with the use of reflective light or roof windows.
- Providing solar panels on roof of south facing buildings is recommended to enhance energy efficiency and sustainability.

This code is applicable to the following area types:
(Those areas where it is applicable are highlighted in colour)

A

B

C

D

E

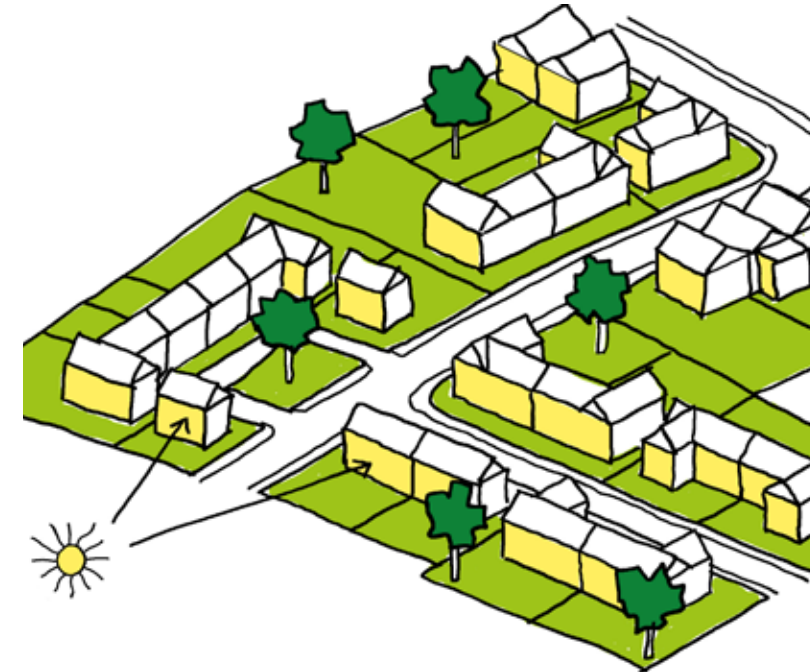
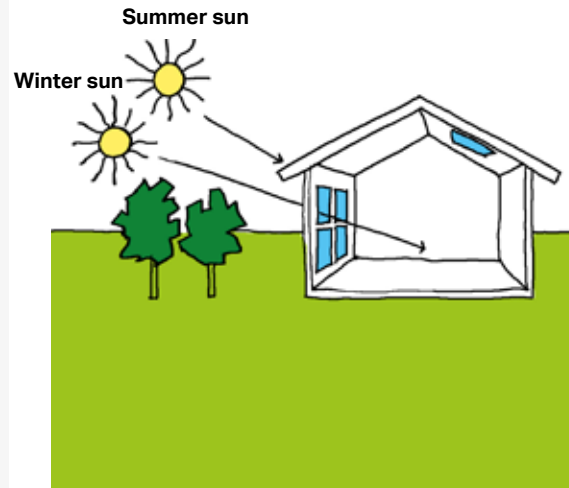

Actions:

- Homes should be designed to avoid overheating through optimisation of glazed areas, natural ventilation strategies via passive/ non mechanical design measures. The natural ventilation strategies include high- and low- level openings, longer roof overhangs deep window reveals and external louvers/ shutters to provide shading in hotter summer months.

Actions:

- One of the main glazed elevations should be within 30° due south to benefit from solar heat gain. Any north-facing façades might have a similar proportion of window to wall area to minimise heat loss on this cooler side.
- If houses are not aligned east-west, rear wings could be included so that some of the property benefits from solar passive gain.

This code is applicable to the following area types:
 (Those areas where it is applicable are highlighted in colour)

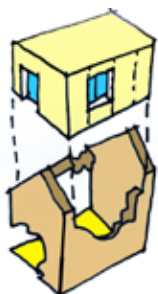

Reuse buildings instead of constructing new ones

Renovation and reuse projects typically save between 50 and 75 percent of the embodied carbon emissions compared to constructing a new building. This is especially true if the foundations and structure are preserved.



Specify low-carbon concrete mixes

Even though emissions per ton are not relatively high, its weight and prevalence usually make concrete the biggest source of embodied carbon in virtually any project.

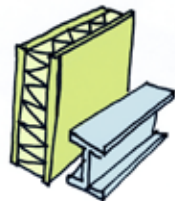

Limit carbon-intensive materials

For products with high carbon footprints like aluminium, plastics, and foam insulation, thoughtful use is essential.

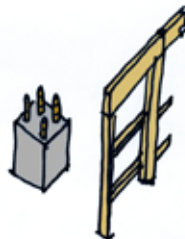

Choose lower carbon alternatives

Think about the possibilities. If you can utilize a wood structure instead of steel and concrete, or wood siding instead of vinyl, you can reduce the embodied carbon in a project.



Choose carbon sequestering materials

Using agricultural products that sequester carbon can make a big impact on the embodied carbon in a project. Wood may first come to mind, but you can also consider options like straw or hemp insulation.



Reuse materials

Whenever possible, look to salvage materials like brick, metals, broken concrete, or wood. Salvaged materials typically have a much lower embodied carbon footprint than newly manufactured materials, since the carbon to manufacture them has already been spent.



Use high-recycled content materials

This is especially important with metals. Virgin steel, for example, can have an embodied carbon footprint that is five times greater than high-recycled content steel.



Maximize structural efficiency.

Because most of the embodied carbon is in the structure, look for ways to achieve maximum structural efficiency. Using optimum value engineering from wood framing methods, efficient structural sections, and slabs are all effective methods to maximise efficiency and minimise material use.



Use fewer finish materials

One way to do this is to use structural materials as finish. Using polished concrete slabs as finished flooring saves the embodied carbon from carpet or vinyl flooring. Unfinished ceilings are another potential source of embodied carbon savings.

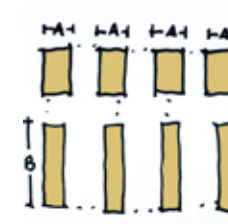

Minimize waste

Particularly in wood-framed residential projects, designing in modules can minimize waste. Think in common sizes for common materials at the design and construction stages.

Materials

About 40 percent of the energy consumed in the United Kingdom in 2020 went directly or indirectly to operating buildings. That figure rises to almost 50 percent when you add embodied carbon—the energy and emissions from materials and construction.

Actions:

- Follow these steps to make significant upfront reductions in embodied carbon emissions at the design and construction stages.

Energy & sustainability

Technology - High Performance Residential Buildings









Energy efficient or eco homes combine all around energy efficient construction, appliances, and lighting with commercially available renewable energy systems, such as solar water heating and solar electricity.

The aim of these interventions is to reduce home overall energy use as cost effectively as the circumstances allow for. Whereas, the final step towards a high performance building would consist of other on-site measures towards renewable energy systems.

Existing homes

- 1  **Insulation**
in lofts and walls (cavity and solid)
- 2  **Double or triple glazing with shading** (e.g. tinted window film, blinds, curtains and trees outside)
- 3  **Low-carbon heating** with heat pumps or connections to district heat network
- 4  **Draught proofing** of floors, walls, windows and doors
- 5  **Highly energy-efficient appliances** (e.g. A++ and A+++ rating)
- 6  **Highly waste-efficient devices** with low-flow showers and taps, insulated tanks and hot water thermostats
- 7  **Green space (e.g. gardens and trees)** to help reduce the risks and impacts of flooding and overheating
- 8  **Flood resilience and resistance** if needed in flood risk areas

New build homes

- A  **High levels of airtightness**
- B  **More fresh air** with mechanical ventilation and heat recovery, and passive cooling
- C  **Triple glazed windows and external shading** especially on south and west faces
- D  **Low-carbon heating** and no new homes on the gas grid by 2025 at the latest
- E  **Water management and cooling** more ambitious water efficiency standards, green roofs and reflective walls
- F  **Flood resilience and resistance** if needed in flood risk areas. E.g. raised electrical, concrete floors and gardens
- H  **Construction and site planning** timber frames, sustainable transport options (such as cycling)
- I  **Solar panel**
- J  **Electric car charging point** particularly where allocated or off-street parking is provided

This code is applicable to the following area types:
(Those areas where it is applicable are highlighted in colour)

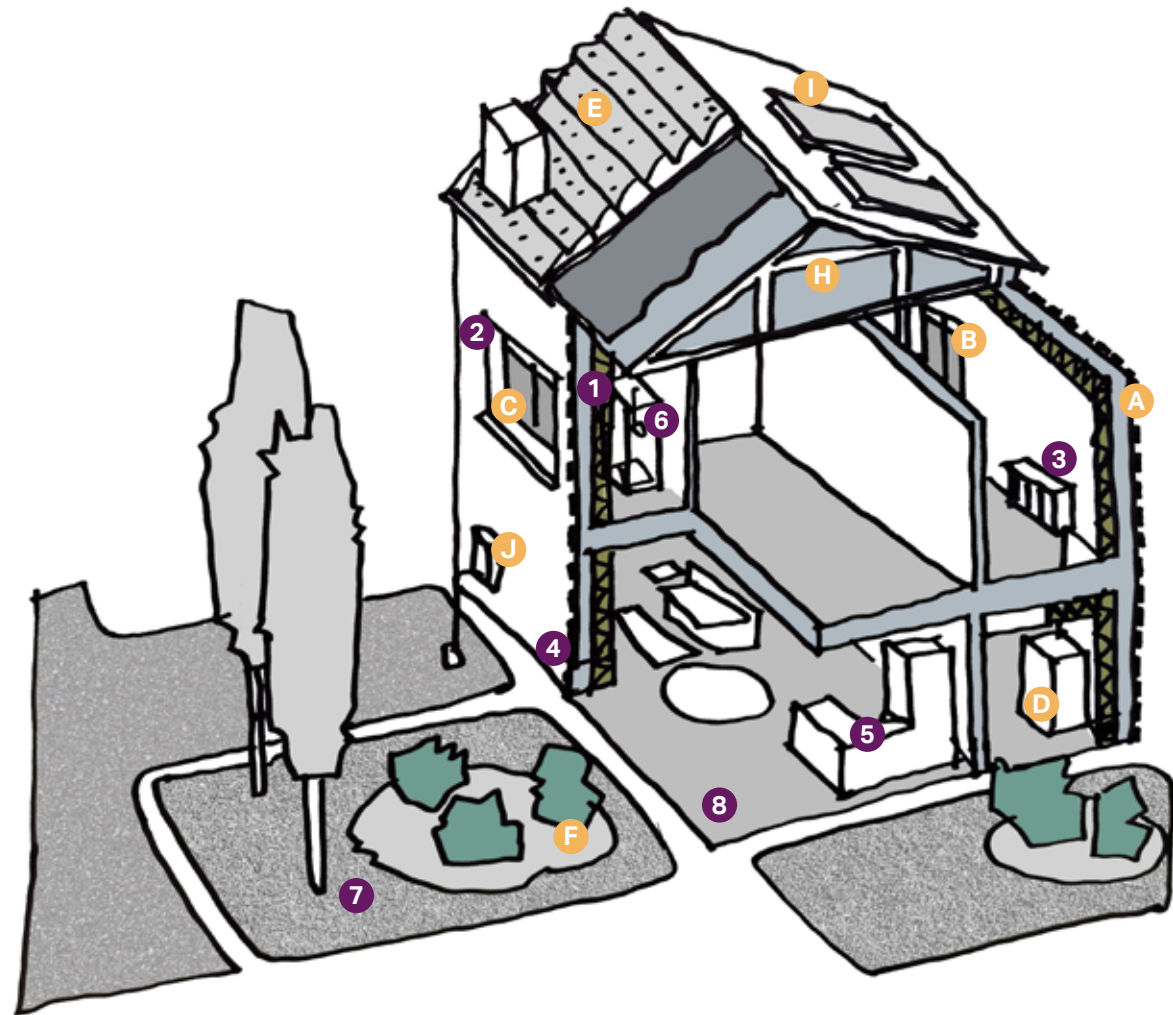

This code is applicable to the following area types:
(Those areas where it is applicable are in colour)



Provide thermal storage in construction elements, such as concrete floor slabs

Provide thermal insulation to any wall or roof to the exterior to prevent heat losses

Pay attention to possible thermal bridges in openings and corners

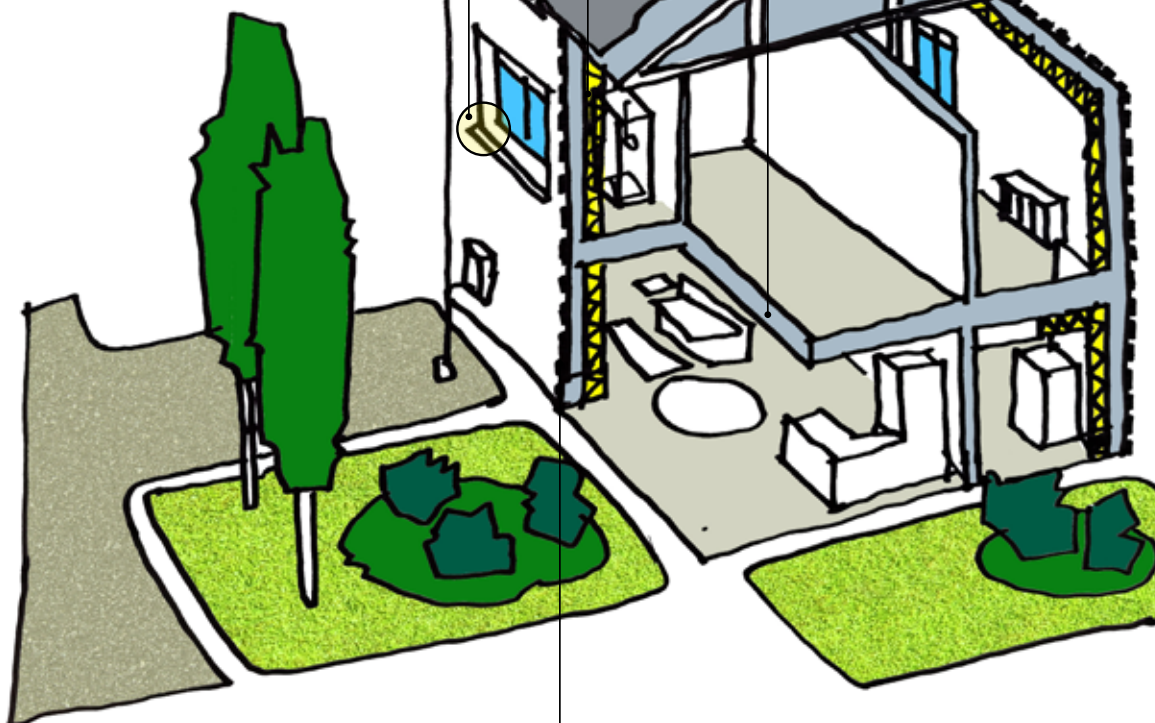

Seal penetrations through the air barrier to guarantee the air tightness of the dwelling

Energy & sustainability

SU.02 Insulation

Thermal mass

Thermal mass describes the ability of a material to absorb, store and release heat energy. Thermal mass can be used to even-out variations in internal and external conditions, absorbing heat as temperatures rise and releasing it as they fall. Thermal mass can be used to store high thermal loads by absorbing heat introduced by external conditions, such as solar radiation, or by internal sources such as appliances and lighting, to be released when conditions are cooler. This can be beneficial both during the summer and the winter.

Actions:

- Provide thermal storage in construction elements, such as a trombe wall placed in front of a south-facing window or concrete floor slabs, that will absorb solar radiation and then slowly re-release it into the enclosed space.
- Use mass combined with suitable ventilation strategies.

Insulation

Actions:

- Provide thermal insulation to any wall or roof to the exterior to prevent heat losses. Pay particular attention to heat bridges around corners and openings in the design stage.
- Provide acoustic insulation to prevent the transmission of sound between active (i.e: living room) and passive spaces (i.e: bedroom).
- Provide fire insulation and electrical insulation to prevent the passage of fire between spaces or components and to contain and separate electrical conductors.

Air tightness

Airtight constructions help reduce heat loss, improving comfort and protecting the building fabric. Airtightness is achieved by sealing a building to reduce infiltration – which is sometimes called uncontrolled ventilation. Simplicity is key in airtightness design. The fewer junctions, the simpler and more efficient the airtightness design will be.

Actions:

- Form an airtightness layer in the floor, walls and roof.
- Seal the doors, windows and rooflights (if applicable) to the adjacent walls or roof.
- Link the interfaces between walls and floor and between walls and roof, including around the perimeter of any intermediate floor.
- Seal penetrations through the air barrier.

Energy & sustainability

SU.03 Solar panels

New houses should incorporate solar panels in their roof design, they should follow this general design guide as appropriate.

Colour & contrast

- The colour and finish of solar panels and how they reflect light should be chosen to fit in with the building or surroundings. The majority of crystalline and thin film panels are dark blue or black; within these shades are a variety of finishes and tones to help make the panels unobtrusive.

Frames

- Panels without frames, or black-framed panels, should be used where framed panels would detract from the building.

Size and style

- Consider the style of the building and, if possible, position the solar PV panels so they are in proportion to the building and its features. For example, they can resemble roofing elements such as roof lights or windows.
- The way in which panels are laid out in relation to one another can make a huge difference to the appearance of the system – favour symmetrical arrangements.
- Consider how the installation relates to the shape of the roof or building. If possible, covering the whole roof or one of its gables is often advisable.

Surroundings

- Choose plant and tree types and locations so that plants will not grow to shade areas on the property or on neighbouring properties where solar energy systems are installed.
- Solar PV on adjacent houses of the same type may look out of place if the approaches are very different. Consider using similar components to fit with the prevalent panel style in the area.

This code is applicable to the following area types:
(Those areas where it is applicable are highlighted in colour)

A

B

C

D

E



Select a colour and finish that matches the surroundings



Consider frameless panels



Proportions of the panels should reflect the language of the building and its elements

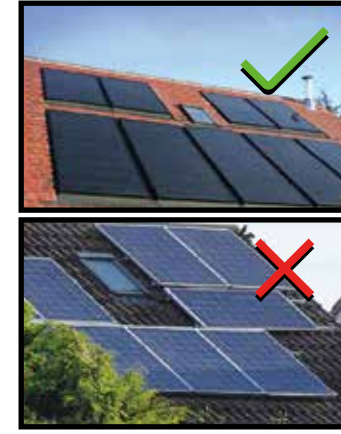

Favour symmetrical arrangements



Often, covering a whole gable is the best way to relate to the general shape of a roof



Plant trees that do not overshadow the panels



Avoid overshadowing neighbouring properties



Maintain a consistent look with neighbouring properties

This code is applicable to the following area types:
(Those areas where it is applicable are highlighted in colour)



Orientate green roofs and walls to optimal sunlight radiation and minimise the effect of overshadowing



Protect green roofs and walls from excessive wind levels, in this case the sloping site assists in the protection of the roof



Favour ease of maintenance and accessibility to the green roof



Green roofs and walls should minimise power use and do not need to be heavily engineered solutions. Climbing plant species such as vines are a traditional way of achieving the same effects

Energy & sustainability

SU.04 Green roofs

Sunlight orientation & overshadowing

- Sunlight, orientation and overshadowing from surrounding buildings have to be taken into account. Care must be taken to ensure that the plants receive sufficient but not excessive sunlight to grow.

Wind exposure

- Wind speed and exposure varies according to building height, orientation and location. The plants, soils and supporting structures must be able to withstand these forces. The plants and structure must be anchored so they cannot detach from the building and cause damage. The soils should be contained so the wind cannot blow them away.

Services

- Green roofs and walls need water, power and drainage for maintenance. Care must be taken to keep roots and leaves out of the drainage system, and this should be factored into design and maintenance. There should be points where the drainage system can be inspected and cleaned out regularly.

Power use

- Green roofs and walls should be designed to minimise power use. Therefore, consider the orientation of the roof and walls, and the access to natural light. Where possible, use gravity and not pumps for watering systems.

Installation

- Green walls should be separated from the building elevations, so there is no moisture transfer to the wall.

Existing buildings and parapets

- Some roof parapets can lead to ponding and pooling of water. If the building has parapets, ensure that there is good drainage. The fitting of high-water alarm systems should be considered if there is no clear overflow path.





2d

Applied design codes

Applied design codes

This section includes a summary of the different design codes and their primary areas of application.

Key

- Area type A: Historic core
- Area type B: Settlement
- Area type C: Rural Countryside
- Area type D: Green Belt
- Area type E: New development

- x** Design code applicable to character area
- Design code not applicable to character area

MO.01	Connectivity
MO.02	Public transport
MO.03	Wayfinding
MO.04	Junctions
MO.05	Inclusive streets
MO.06	Car parking
MO.07	Cycle & refuse storage

NA.01	Green Belt
NA.02	Green Networks
NA.03	Design with water
NA.04	SuDS
NA.05	Net gain
NA.06	Biodiversity
NA.07	Street planting
NA.08	New woodland

BF.01	Density
BF.02	Types & forms
BF.03	Heights
BF.04	Building line

ID.01	Local character
ID.02	Legibility
ID.03	Heritage Assets
ID.04	Plots & blocks

	A	B	C	D	E
MO.01	x	x	x	x	x
MO.02	x	x	-	-	x
MO.03	x	x	x	-	x
MO.04	-	-	x	-	x
MO.05	-	-	x	-	x
MO.06	-	-	x	-	x
MO.07	-	-	x	-	x
NA.01	-	-	-	x	-
NA.02	x	x	x	x	x
NA.03	x	x	x	x	x
NA.04	x	x	x	x	x
NA.05	-	-	x	-	x
NA.06	x	x	x	x	x
NA.07	x	x	x	-	x
NA.08	-	-	x	x	x
BF.01	x	x	x	x	x
BF.02	x	x	x	x	x
BF.03	x	x	x	x	x
BF.04	-	-	x	-	x
ID.01	x	x	x	x	x
ID.02	x	x	x	x	x
ID.03	x	x	x	x	x
ID.04	-	-	x	-	x

		A	B	C	D	E
PS.01	Access street	-	-	x	-	x
PS.02	Residential street	-	-	x	-	x
PS.03	Tertiary street	-	-	x	-	x
PS.04	Secured by design	x	x	x	-	x
US.01	Shops	-	-	-	-	x
US.02	Community uses	-	-	-	-	x
HO.01	Space standards	-	-	x	-	x
HO.02	Accessibility	-	-	x	-	x
HO.03	Gardens	x	x	x	x	x
HO.04	Extensions	x	x	x	x	x
SU.01	Low carbon	-	-	x	-	x
SU.02	Insulation	-	-	x	-	x
SU.03	Solar panels	x	x	x	x	x
SU.04	Green roofs	x	x	x	x	x





04

Delivery

Delivery

These design codes consider the spatial and contextual character of Ickleford and subsequently set out the conditions that any development in the area should follow. These codes inform how future developments might create high quality places in a way which responds to and enhances the rich character of the area.

These design codes can be a valuable tool for securing context-driven, high quality development in Ickleford, especially on allocated sites and in potential sites that might come forward in the future. They will provide more certainty to both developers and the community in securing developments that are designed to the aspirations of the community and that can speed up the planning process.

These design codes are anticipated to be used by different stakeholders in the planning and development process in the various ways summarised in the table opposite.

Stakeholders	How to use this guideline
Applicants, developers, landowners	As a guide to community and Local Planning Authorities expectations on design, allowing a degree of certainty – they will be expected to follow these guidelines as planning consent is sought.
Local Planning Authority	As a reference point, embedded in policy, against which to assess planning applications. The design codes should be discussed with applicants during any pre-application discussions.
Parish Council	As a guide when commenting on planning applications, ensuring that the design codes are complied with.
Community organisations	As a tool to promote community-backed development and to inform comments on planning applications.
Statutory consultees	As a reference point when commenting on planning applications.

About AECOM

AECOM is built to deliver a better world. We design, build, finance and operate infrastructure assets for governments, businesses and organizations world-wide. As a fully integrated firm, we connect knowledge and experience across our global network of experts to help clients solve their most complex challenges. From high-performance buildings and infrastructure, to resilient communities and environments, our work is transformative, differentiated and vital. See how we deliver what others can only imagine at aecom.com

Contact

Ben Castell

Director - Design, Planning and Economics

M +44 (0)7739 498 458

E: ben.castell@aecom.com